



FRANKFORD UMBRELLAS
NORTH AMERICAN HEADQUARTERS

110 Gaither Drive
Mount Laurel, New Jersey 08054
856-222-4134

Info@frankfordumbrellas.com
frankfordumbrellas.com

    @frankfordshade

AURORA

OPERATION AND INSTALLATION MANUAL



FRANKFORD
exceptional shade

TABLE OF CONTENTS

BEFORE INSTALLING

- 01** GRUB-SCREWS
- 03** HARDWARE AND CORRESPONDING BASES
- 09** GUIDELINES TO CONSIDER BEFORE INSTALLING
- 10** ALIGNMENT AND SPIGOT INFORMATION

GENERAL OPERATION INFORMATION & CARE

- 05** GENERAL OPERATION INFORMATION
- 06** SIMPLE MAINTENANCE PROCEDURES

FABRIC CARE

- 07** FABRIC CARE / LONGEVITY
- 08** CASUAL / INTENSIVE FABRIC CARE & CLEANING

UMBRELLA OPERATIONS

- 11** OPENING AURORA CANTILEVER UMBRELLA
- 12** CLOSING AURORA CANTILEVER UMBRELLA
- 13** ROTATING THE AURORA CANTILEVER UMBRELLA
- 14** INSTALLING THE WIND STABILIZER KIT
- 15** AURORA PARTS KEY

BASES & MOUNTING INSTALLATION

- 17** IN-GROUND
- 19** WOOD DECK SURFACE
- 21** CONCRETE/SOLID SURFACE
- 23** 40G+36G ROUND GALVANIZED PLATE STACK
- 25** 36Gx2 SQUARE GALVANIZED PLATE STACK
- 27** ARU-480 ROLLING BASE
- 29** XB-MODULAR CROSS BASE
- 31** +C MODULAR CROSS BASE COVER ASSEMBLY

WIND RATING & WARRANTIES

- 02** WIND RATING
- 33** RESIDENTIAL WARRANTY
- 34** COMMERCIAL WARRANTY

BEFORE INSTALLING

REMOVE GRUB-SCREWS

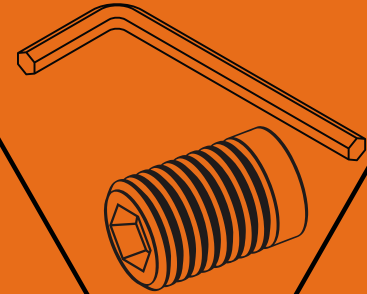

THE FUNCTION OF GRUB-SCREWS ARE ONLY TO PROTECT THE THREADS IN WAREHOUSE STORAGE AND SHIPPING. ONCE REMOVED, PLEASE DISCARD AND DO NOT LEAVE IN THE BASE. THEY ARE NOT CORROSION RESISTANT AND WILL RUST IF EXPOSED TO THE ELEMENTS.

- **GRUB-SCREWS ARE IN PLACE TO KEEP THE THREADED HOLES CLEAN AND FREE FROM DIRT, SAND ETC.**
- **ONCE YOUR BASE IS IN PLACE, USE THE SUPPLIED ALLEN KEY TO REMOVE ALL GRUB-SCREWS BEFORE INSTALLING THE UMBRELLA.**
- **YOU MAY RECEIVE ADDITIONAL MOUNTING HARDWARE WITH YOUR UMBRELLA THAT IS NOT NEEDED FOR YOUR SPECIFIC MOUNTING SELECTION.**
- **DO NOT DISCARD THIS ADDITIONAL MOUNTING HARDWARE IN CASE YOU DECIDE TO CHANGE YOUR MOUNTING OPTION IN THE FUTURE.**

AURORA CANTILEVER UMBRELLAS ARE ENGINEERED TO WITHSTAND 25MPH SUSTAINED WINDS AT AN OPTIMAL 90° ANGLE. THE ADDITION OF THE WIND STABILIZER KIT INCREASES THIS TOLERANCE BY 5MPH.

DO NOT ATTEMPT TO OPEN OR UTILIZE THE TILT FEATURE AT ANY DEGREE OF TILT IN WINDY CONDITIONS.

Frankford Umbrellas have been tested successfully in extreme weather and winds, however, we strongly recommend closing your umbrella when not in use, or in moderate sustained winds.

WIND RATING

Wind ratings do NOT form part of, nor fall under, any Frankford Umbrellas' warranties. Wind ratings are intended as a guide to the relative strength of the umbrellas only and tested at their optimal 90° and non-tilted positions. Umbrellas with any degree of tilt added should not follow the above wind ratings. Wind can be extremely variable, depending on the surroundings, elevation, angle of gusts, etc. In any high wind or sudden extreme weather conditions, all umbrellas should be closed and secured immediately.

Frankford can recommend specific bases and anchoring systems for specific umbrella types. However, these are only recommended weights, as different environments may require different base options. Please contact us for assistance in choosing the proper umbrella base or anchoring system.

In the event Frankford shade products are left open and/or unattended in harsh weather conditions, our customer service department is here to help you and promptly assist with parts for repairs. Our shade products offer modular, self-repairable components which allow customers to service the umbrellas to keep them in perfect working condition.

HARDWARE AND CORRESPONDING BASES

MOUNTING HARDWARE FOR BASES, IN-GROUND & SURFACE MOUNTS

PLEASE BE AWARE OF HARDWARE NEEDED FOR SPECIFIC BASES. NOT ALL HARDWARE WILL WORK WITH ALL BASE CONFIGURATIONS AND OR MOUNTS.

You may receive additional mounting hardware with your umbrella that is not needed for specific mounting selection. Please see the specific mounting installation pages in this manual for your specific hardware needed, and detailed mounting instructions.

GRUB-SCREWS ARE IN PLACE TO PROTECT THE THREADED HOLES ON BASES DURING SHIPPING AND STORAGE. THEY MUST BE REMOVED AND DISCARDED BEFORE THE INSTALLATION OF ANY UMBRELLA.



1:1 SCALE

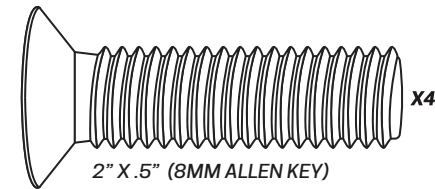

TRIPLE GALVANIZED PLATE STACK

- FOR USE WITH TRIPLE PLATE STACK OPTIONS

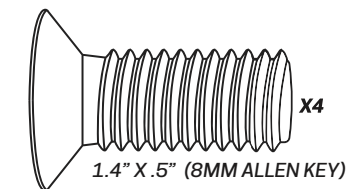

DOUBLE GALVANIZED PLATE STACK

- 40+36G
- 36G-SQX2
- XB - CROSS BASE

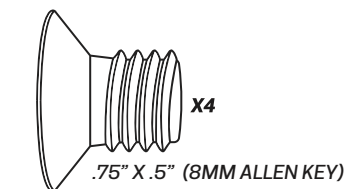

- DECK PLATE (SURFACE MOUNTING)
- IG (IN-GROUND MOUNTING)
- ARU-480 ROLLING BASE

GUIDE PINS [SCAN THE QR-CODE FOR VIDEO TUTORIAL](#)

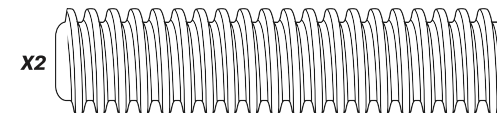

SCAN THE QR-CODE FOR THE VIDEO TUTORIAL ON HOW TO PROPERLY AND EFFICIENTLY STACK THE G-PLATES USING FRANKFORD GUIDE PINS.

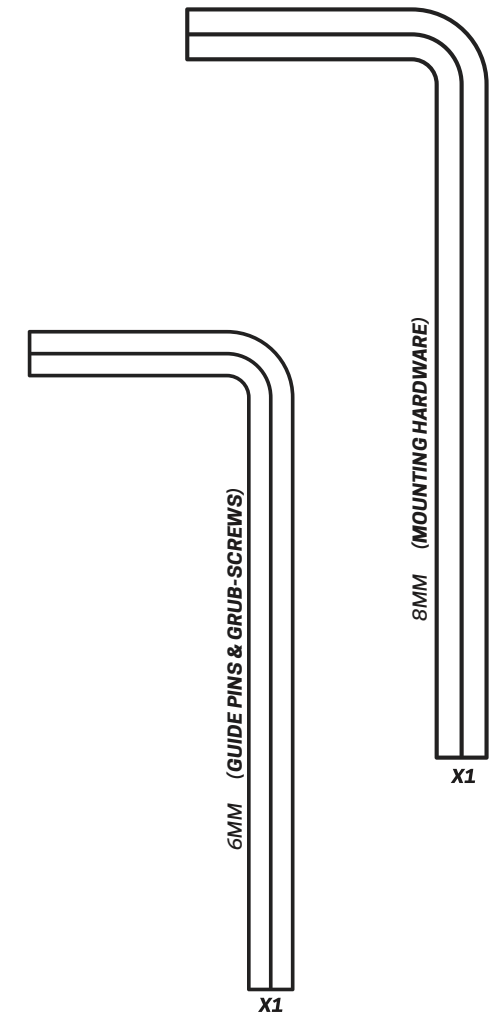

GENERAL INFORMATION

Your Aurora Cantilever Umbrella is principally intended for use in low to moderate wind conditions and will provide you with many hours of protection from sun and light rain. You will get maximum benefit from your umbrella when you use it in accordance with our instructions and in the weather condition for which it was designed.

- Do not attempt to open the umbrella in windy conditions. This may cause unwanted stress on the cranking system as the large umbrella canopy needs to work against the winds.
 - Before you begin to open your umbrella, be sure to loosen the Slider Car Knob **(26)** so that the Slider Car can travel freely and float along the mast while cranking. Tighten the Slider Car Knob **(26)** into position only when the canopy is fully open.
 - When you first open your umbrella, the fabric will be stiff and you will notice a 1-3” gap between the Hub Tube **(12)** and Tube Locator **(10)**. This is normal and as the fabric relaxes this connection will seat perfectly when fully open.
 - **DO NOT PUSH THE SLIDER CAR UP INTO ANY DESIRED POSITION BEFORE THE UMBRELLA CANOPY IS FULLY OPEN. THIS IS TO MAINTAIN TENSION ON THE CABLE SYSTEM TO AVOID ANY KINKING OR TANGLING, RENDERING THE UMBRELLA INOPERABLE.**
 - “Fluffing The Ribs” - When the umbrella is fully closed, the ribs will pass a 180° angle hindering them from opening from simply cranking. Give the ribs a slight pull out from the hub (“fluff”) while cranking.
 - Do not leave umbrella open when unattended, particularly in windy conditions. Your Aurora Umbrella should be closed and securely strapped in strong winds and adverse weather conditions.
 - When using the Wind Stabilizer bars, your Aurora should be at it’s 90° locked angle, and Slider Car Knob **(26)** tightened. The Wind Stabilizer bars are not to be used when the umbrella is in any degree of tilt.
 - Always secure your umbrella to a Frankford base that is appropriate to the environment in which it is going to be used.
 - Be careful when closing to ensure the canopy does not get caught or “pinched” by the umbrella arms.
 - After the umbrella is closed, remove the inward fold by pulling fabric panels “out” from the center
 - Once all fabric panels are pulled, fold one over the other towards the front face of the canopy
 - Firmly wrap the supplied Velcro fabric strap and place the protective cover over your umbrella
- This is particularly important before storing the umbrella away for extended periods of time or if the umbrella is to be laid horizontally for storage. Damage to the fabric caused by “pinching” is not covered by the warranty. Follow all manufacturer’s assembly instructions.
- Make sure your Aurora is dry and clean prior to storing away for extended periods of time to prevent mold from developing on dirt and directly onto the fabric.
 - Inspect the installation fitting/base on a regular basis and tighten as necessary.
 - Please avoid any modifications to your umbrella, except those made by an authorized Frankford customer service agent. Unauthorized modifications will void the warranty.

Congratulations on purchasing your Aurora Cantilever Umbrella. The Aurora is manufactured using the highest materials and fabrics on the market, and is perfectly designed to give you many years of enjoyment. The following information will explain how to operate your Aurora Cantilever Umbrella to ensure trouble free use and ease of operation. Please follow these instructions as they are designed to assist operation and prolong the life of your umbrella.

SIMPLE MAINTENANCE PROCEDURES

Your Aurora Cantilever Umbrella is virtually maintenance free. The tips below should aid in the overall longevity of the product and keep the umbrella working optimally for years to come.

- In coastal or metropolitan environments, frequent washing of the complete unit is beneficial. Particularly the slider car, slider car guide tracks, and rotating mechanism.
- If you are in a coastal environment, a simple spraying of fresh water to remove any salt water and salt air deposits on the aluminum that could cause calcium buildup and lead to having to do more intensive cleanings.
- If extensive calcium buildup or hard water stains are an issue, this can be remedied with 2tbsp of white vinegar per every quart of boiled fresh water and a soft bristle brush.
- Should the 16 rotating mechanisms stop pin holes become filled with sand or dust etc., lifting your umbrella up off the Spigot **(35)** by 1” will allow the dust cover to be lifted and the 16 holes can be cleaned. This will be a two person operation.
- Spraying silicon spray in the Slider Car and visible pulley wheels will assist operation if required and a good idea before storing away for a season.
- Fold the acrylic canvas as mentioned in “Closing The Aurora” (Page 12). This will prolong the new look of the fabric and prevent marking caused by “pinching” in the alloy frame.
- All parts are virtually maintenance free (e.g. aluminum, stainless steel, etc.) However, the above mentioned care is recommended to increase the overall longevity of the umbrella.
- If the umbrella is not to be used for an extended period of time (winter months), you may remove the umbrella from the Spigot **(35)**, place in storage and then remove the Spigot as it can be a tripping hazard.
- The included protective cover should be used when the umbrella will not be operated for an extended period of time.

FABRIC CARE

Recacril® Marine Grade Acrylic Fabric Infinity Process is a highly technological finish, providing Recacril with long lasting protection against mold and mildew, excellent water and oil repellency and protection from both sun and water. However, the accumulation of dust, pollution particles, foreign organic materials, and general dirt can damage this protection, shortening the life of the RECacril, so they should be removed. The most effective method for maintaining Recacril® is to clean the canvas once a month with water using a low-pressure hose. It is very important that after cleaning with water, the canvas be allowed to completely dry before rolling or storing your umbrella. If for any reason you have to roll and/or store a wet umbrella, it must be unrolled and opened as soon as possible to let it dry. In times of continuous rain, it is advisable to keep the umbrella rolled and stored.

If periodic washing with water is done, in most environments, you should only need to do a more thorough cleaning every 2-3 years.

FABRIC LONGEVITY

When the umbrella is closed, you'll notice the weight of the fabric from the panels will tuck and fold in towards the center hub and becoming pinched between the ribs of the frame. Leaving the fabric in this state will cause premature wear and tear. Simple friction of constant rubbing and the pinching can cause micro tears and pinholes on the fabric. This is not detrimental to the integrity of the fabric's overall state, however continued neglect over time the tears and pinholes will increase in size and cause a premature replacement of the canopy.

To prevent this, after closing the umbrella, pull the panel fabric out and fold each panel in an over/over method before wrapping with the supplied Velcro fabric tie.

CASUAL CARE & CLEANING

- Brush off dust and dirt with a soft brush. NEVER brush with stiff brushes since this can damage the fabric finish.
- Spray the umbrella with clean water. If a hose is used, avoid high pressure.
- Prepare a solution of solvent-free soap in warm water (no more than 100°F) and apply it to the fabric and stitching.
- Scrub with a soft brush, allowing the solution to penetrate the fabric.
- Rinse with water to remove all traces of soap.
- Let air dry and do not close the umbrella until the canvas is completely dry.
- **DO NOT USE MAJORITY BLEACH BASED DETERGENTS TO CLEAN THE UMBRELLA CANOPY.**

INTENSIVE CARE & CLEANING

Recacril® is highly resistant to the growth of fungus, mold, and mildew. However, these can grow on embedded dirt. To clean these stains, follow these more intensive cleaning procedures.

- Brush off dust and dirt with a soft brush. NEVER brush with stiff brushes as this can damage the fabric finish.
- Prepare a solution with 10% household bleach, 20% solvent-free neutral detergent (Free & Clear detergents) and 70% water.
- Apply the solution to the fabric, allowing to remain between 15 and 20 minutes maximum.
- Rinse with clean water several times. Any bleach residues remaining on the canvas, combined with the sun, could damage the fabric and stitching.
- Let air dry and do not close the umbrella until the canvas is completely dry.
- Repeat the process if necessary.
- **DO NOT USE MAJORITY BLEACH BASED DETERGENTS TO CLEAN THE UMBRELLA CANOPY.**

GUIDELINES TO CONSIDER BEFORE INSTALLING

ROTATIONAL SPACE

Be aware of the clearance space required if you wish to rotate your umbrella. Nearby walls, trees, fences or a building can limit this umbrella feature. Positioning your umbrella in a corner can severely limit your space to rotate.

CHECK THE SPACE

Where possible, we recommend the umbrella is stood up in the desired installation location, and fully opened before installing the ground anchors. This is to ensure that the umbrella will fit and that the installation location is correct. We recommend this is done in little or no wind.

OPENING ARC

When choosing a location to install your umbrella, it is important to be aware of the umbrella's arm closing height and opening arc. Your umbrella may connect with a wall, fence or furniture if situated too close.

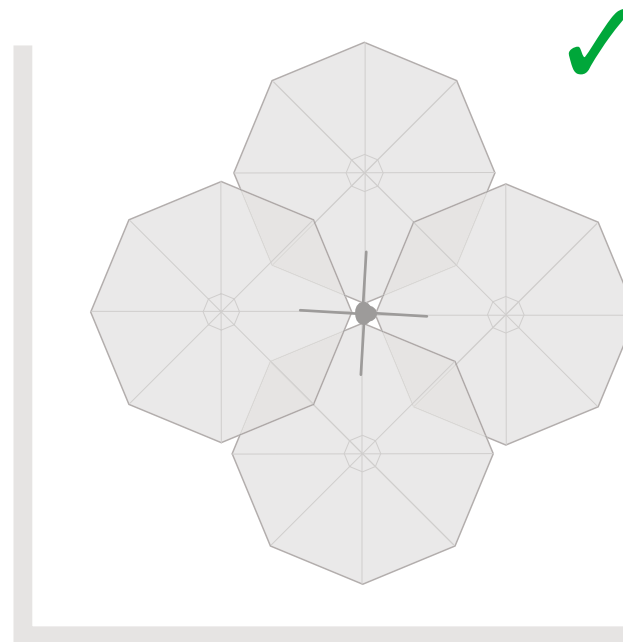

A good rule of thumb when installing an umbrella with full 360° ROTATION, measure for canopy depth fully and rotate for clearance.

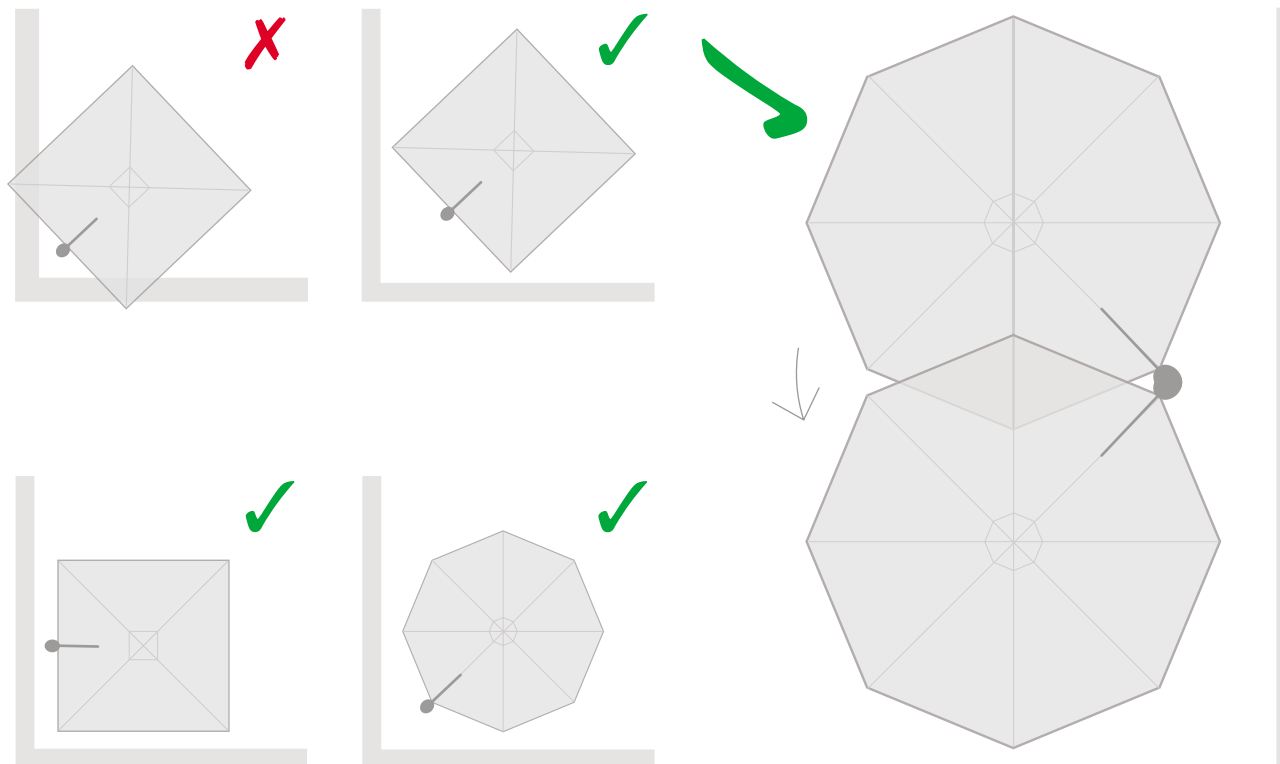

Your Aurora Cantilever Umbrella is delivered fully assembled. There are four different ways to install your Aurora Cantilever Umbrella:

1. Installing on a wooden deck using a Deck Plate.
2. Installing on an existing concrete slab or pavers using a Deck Plate.
3. Installing into the ground (i.e. into a lawn, garden or paved patio) using the In-Ground mount.
4. Installing on a free-standing base.

Prior to installing your installation mounts please read the important information below.

ALIGNMENT

Your Aurora Cantilever Umbrella can rotate 360° and be locked in 16 different locations. This means that every 22.5° of rotation there is provision to lock the umbrella. In most situations there will be a preferred area over which you will predominantly want shade. To ensure you have the ability to shade your preferred location you must have one of the 22.5° rotation locking holes (**Figure A**) in line with this position. Please have a look at the underside of your Spigot (**35**) to see these 16 locking holes

There is a locking hole in line with each of the 4 Spigot bolt holes in the Spigot plate. There are also three intermediate holes between each of the Spigot bolt holes and these are marked with an indicator mark on the top of the Spigot plate.

To point your umbrella in the perfect direction or to have a symmetrical installation (especially when installing square umbrellas) it is very important to make sure you install the Base Plate or In-Ground mount square to the direction that you predominantly want the umbrella to point.

SPIGOT

Your Aurora Cantilever come with the Spigot (**35**) already inserted in the mast of your umbrella. It is an integral part to the installation and mounting of your umbrella.

The Spigot is secured within the mast of the Aurora by the Spigot Locking Pin (**36**). Pull this button and slide the Spigot (**35**) out from the mast.

1. You can mount the spigot to your choice of installation first, and then secure your Aurora by lifting over and onto the Spigot (**35**) until you hear an audible "click" from the Spigot Locking Pin (**36**), indicating your umbrella is now secure.

2. You can leave the Spigot (**35**) inside of your Aurora and mount the umbrella and Spigot together as a whole to your choice of installation.

Figure A

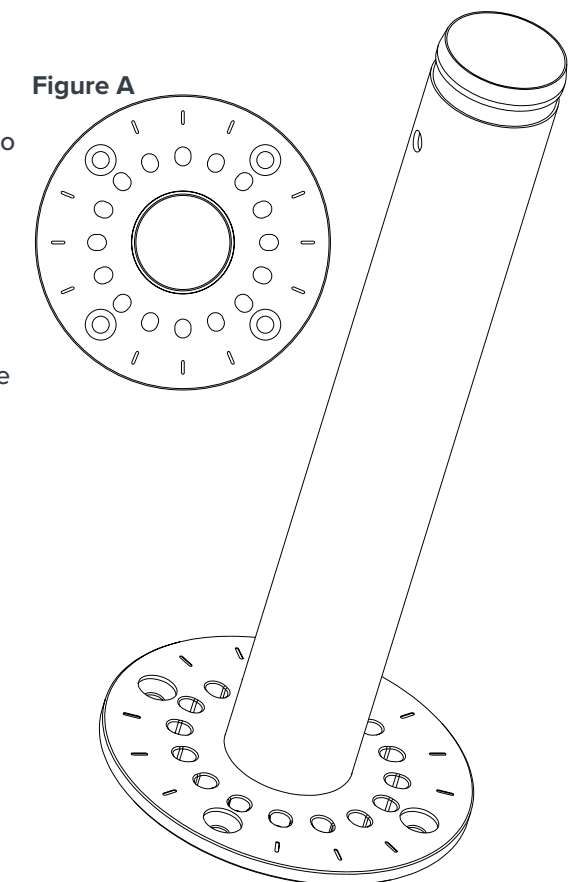

OPENING AURORA CANTILEVER UMBRELLA

1. Remove the protective cover by unzipping from the front. There will be two rods inserted into the cover, use the rods to lift up and over towards the back (mast) of the umbrella.
2. Towards the bottom of the mast, move your attention to the Slider Car/Knob (26), and loosen the knob. Your canopy will shimmy slightly.
3. Locate the crank handle (28) that is packed with your umbrella and insert into the indentation on the mast.

DISCLAIMER: Do not move the slider car into a desired position until the canopy is 2/3 - fully open. The cable system must maintain tension through the opening and closing process.

4. Before cranking, gently spread/"fluff" umbrella arms (Figure B) and begin to crank your umbrella clockwise. If you feel any impingement whatsoever, halt cranking and fluff your umbrella once more.
5. As the canopy opens, the Infinity Tilt Knob (27) should travel freely and begin to "float" on the mast (this is normal). When your umbrella is almost half way open, you can begin to push the Slider Car up to it's Highest position until it stops, and tighten the Infinity Tilt Knob (27). Continue to crank until umbrella is fully open.
6. At this point, your umbrella should be fully open and at a horizontal position, and the Infinity Tilt Knob (27) should be tightened. To Tilt into a desired position, hold on to the Infinity Tilt Knob (27), loosen and slide into your preferred tilt angle. Once set, tighten the knob (27) and you're ready to enjoy.

IMPORTANT:

- Do not attempt to open the umbrella in windy conditions. This may cause unwanted stress on the cranking system as the large umbrella canopy needs to work against the winds.
- Avoid extreme angles in any windy situations. Always set at 90° when gusty or in moderate winds with the Wind Stabilizer Kit.
- The Wind Stabilizer Kit can ONLY be used while the umbrella is at it's optimal 90° position, locked and the knob is tightened. This kit cannot and used while the umbrella is at any degree of tilt.



CLOSING AURORA CANTILEVER UMBRELLA

1. Loosen the Infinity Tilt Knob (27) and let the Slider Car (26) free float.

DISCLAIMER: Do not move the slider car into a desired position until the canopy is 2/3 - fully open. The cable system must maintain tension through the opening and closing process.

2. Begin to crank counter-clockwise. As the umbrella starts to close, you can manually help the Slider Car (26) down the mast.
3. When the canopy is fully closed, pull the Main Arm (20) towards the mast ensuring the Slider Car (26) is at it's lowest point and then tighten the Infinity Tilt Knob (27), locking the Slider Car (26) down.
4. When the umbrella is closed, you'll notice the weight of the fabric from the panels will tuck and fold in towards the center hub and becoming pinched between the ribs of the frame. Leaving the fabric in this state will cause premature wear and tear.
 - After closing the umbrella, pull the panel fabric out and fold each panel in an over/over method before wrapping with the supplied Velcro fabric tie. This will ensure avoidable wear and tear on the fabric with simple maintenance.
5. Secure the folded panels in place with the canopy strap (B), wrapping it firmly around the mast and canopy. Gently push the folded canopy back against the mast so that it is compact and the rubber bump-stops are in contact with the Mast (22).

- **PLACING THE PROTECTIVE COVER:** Stand in front of the folded canopy and open the protective cover zipper completely. Use the handle rod to lift the protective cover behind the mast and up as high as possible to clear the top of the umbrella. Pull the protective cover down over the top of the mast (22) and canopy. Zip the protective cover closed. The zip should be on the front side of the canopy (C), not at the back of the mast.



ROTATING THE AURORA CANTILEVER UMBRELLA

- **NOTE:** There are 16 rotational-locking holes in the spigot. These location holes are found at every 22.5° intervals around the spigot plate (**Figure A**). They are located where indicated on the top of the spigot base and are under the nylon indexing shield (34) which acts as a dust cover for the holes not in use.

SPIGOT PLATE

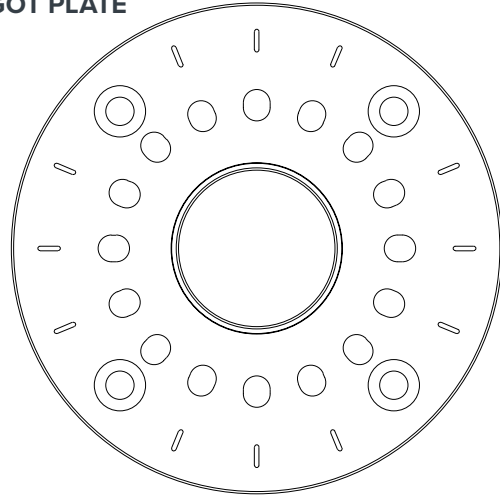

1. Lift the rotation handle (**32**), releasing the pin from the initial position (**Figure A**).
2. Lift up on the handle and feel the resistance from the spring that houses the rotating lock pin.
3. By using the rotating-lift handle (**32**) as a lever, you can rotate the umbrella on the base (**Figure B**) until you arrive at the new desired position.
4. Each position is marked by a notch on the spigot plate. Align the indicator arrow with a notch (**Figure C**). Once aligned with a notch, lower the rotating handle to engage the rotating-lock pin.

- **IMPORTANT:** Do not force the rotating handle down if the indicator arrow is between notch positions. The rotating handle should close easily. If any resistance is encountered do not force it, rotate the umbrella further until the pin engages in a locking hole.

- **DO NOT USE THIS HANDLE TO LIFT THE UMBRELLA OFF OF THE SPIGOT.**



FIGURE: A
Lift rotation handle



FIGURE: B
Rotate the umbrella by using the handle

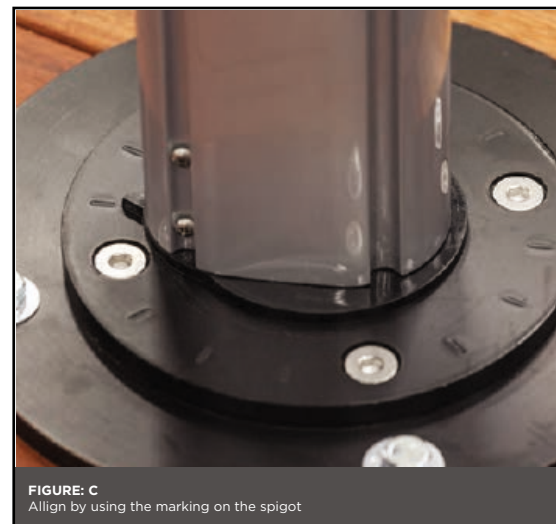

FIGURE: C
Align by using the marking on the spigot

INSTALLING THE WIND STABILIZER KIT

IMPORTANT:

- **The Wind Stabilizer Kit can ONLY be used while the umbrella is at its optimal 90° position indicated by the locking pin, and the knob is tightened. This kit cannot be used while the umbrella is at ANY DEGREE OF TILT.**

1. While the umbrella is open, slide the stay block (**34**) to the height of the stabilizer bars. Begin to thread into the stay block using the thumb-screw.
2. Attach the threaded stainless screw (with the two aluminum bars attached) to the stay block in the mast and tighten the screw sufficiently for the stay block to remain in position without sliding down the mast (**Figure B**).
3. Swing either aluminum-stay arm off the ground and attach to the umbrella arms using the Star Thumb-Screw fittings. (**Figure C**).
4. You may need to loosen the locking knob (**Figure B**) and adjust up or down the mast for the stabilizer arms to reach the correct position on the arms (**Figure C**). Once both stabilizer arms have been attached, tighten the central threaded-locking knob to lock in position.

- **NOTE:** The wind stabilizer kit is not needed for normal operation in calm to moderate wind conditions. However for higher wind environments or for commercial applications it is advisable to fit the stabilizer kit to add stability to the umbrella.

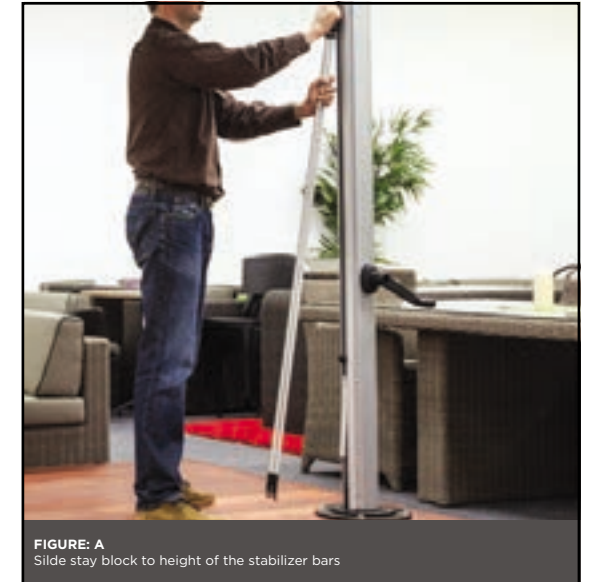

FIGURE: A
Slide stay block to height of the stabilizer bars

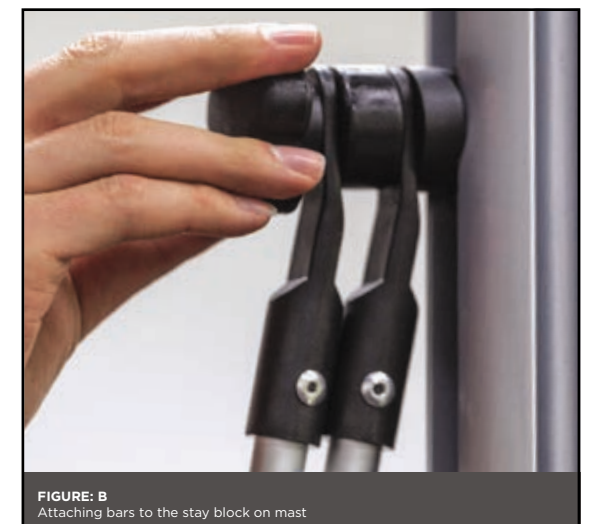

FIGURE: B
Attaching bars to the stay block on mast

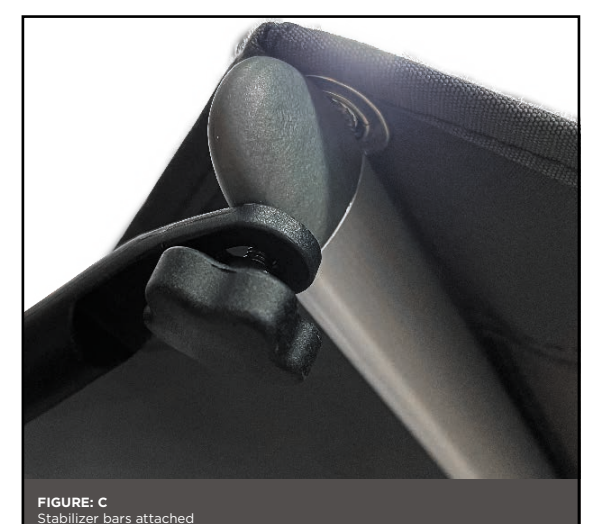
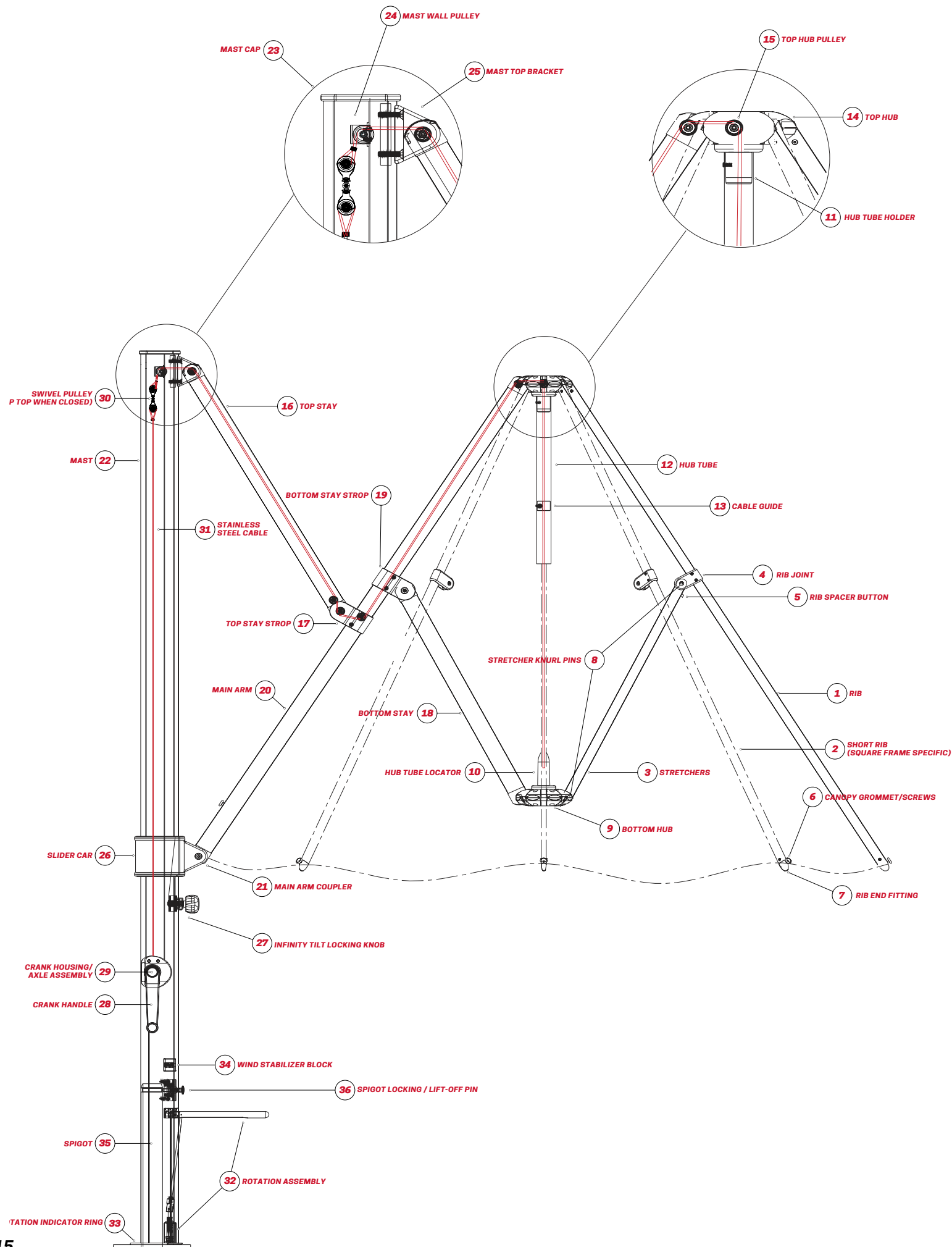

FIGURE: C
Stabilizer bars attached

NOT AVAILABLE FOR AURORA FIBERGLASS

AURORA PARTS KEY

When the Aurora canopy is closed, the stainless steel cable pulley (30), are near the top of the mast. When Aurora canopy is open, the pulley (30) are lower down the mast towards the mid point.



- 1 RIB
- 2 SHORT RIB (SQUARE CANOPY SPECIFIC)
- 3 RIB STRETCHER
- 4 RIB JOINT
- 5 RIB SPACER BUTTON
- 6 CANOPY GROMMETS / SCREWS
- 7 RIB END FITTING
- 8 STRETCHER KNURL PINS
- 9 BOTTOM HUB
- 10 HUB TUBE LOCATOR
- 11 HUB TUBE HOLDER
- 12 HUB TUBE
- 13 CABLE GUIDE
- 14 TOP HUB
- 15 TOP HUB PULLEY
- 16 TOP STAY
- 17 TOP STAY STROP
- 18 BOTTOM STAY
- 19 BOTTOM STAY STROP
- 20 MAIN ARM
- 21 MAIN ARM COUPLER
- 22 MAST
- 23 MAST CAP
- 24 MAST WALL PULLEY
- 25 MAST TOP BRACKET
- 26 SLIDER CAR
- 27 INFINITY TILT LOCKING KNOB
- 28 CRANK HANDLE
- 29 CRANK HOUSING/CRANK AXLE ASSEMBLY
- 30 SWIVEL PULLEY (TOP WHEN CLOSED)
- 31 STAINLESS STEEL CABLE
- 32 ROTATION ASSEMBLY
- 33 ROTATION INDICATOR RING
- 34 WIND STABILIZER BLOCK
- 35 SPIGOT
- 36 LIFT OFF PIN

AURORA

IN-GROUND INSTALLATION



GRUB-SCREWS ARE IN PLACE TO PROTECT THE THREADED HOLES ON BASES DURING SHIPPING AND STORAGE. THEY MUST BE REMOVED AND DISCARDED BEFORE THE INSTALLATION OF ANY UMBRELLA.

Your Aurora Cantilever comes with the Spigot already inserted in the mast of your umbrella. Once you have properly installed your In-Ground Mount, remove the Spigot from your umbrella and you can begin to mount your Spigot to the Deck Plate, and then the umbrella. (see **FIGURE 4**).

IMPORTANT: Where surface terrains differ, a different sized footing hole must be prepared and a different volume of concrete used. As a guide only; a hole 16" wide x 18" deep is recommended for heavy soil terrain. If installing the mount into topsoil or sand, you will need a larger hole and more concrete. We would recommend increasing the depth of the hole, however, it's best that you seek appropriate advice from a licensed contractor for your specific circumstances.

TOOLS & MATERIALS NEEDED

- Spade (Shovel), Tamping Bar or Clamshell Digger
- Level
- Tape Measure
- Rebar (Optional)
- Quick Dry Concrete

1. Locate and Identify your clearing to install your In-Ground mount. Be aware of the size of the umbrella and rotation of the umbrellas when considering your placement.
2. When measuring out the size of your concrete set, you're going to double the width of the footing of the In-Ground mount. 16" wide by 18" Deep. Be sure to flare the bottom of the hole wider than the bore. (**FIGURE 1**)
3. **OPTIONAL:** If you are using rebar to reinforce or wood planks to frame the concrete setting, place your supports around the perimeter, leaving the center of the footing open for the In-Ground mount to settle (**FIGURE 2**).
4. Pour pea gravel in at about 3" deep then using a tamping bar or a piece of wood, tamp down the gravel. After you have a nicely compact gravel set, pour another 3" of pea gravel on top of the tamped layer (**FIGURE 2A**).
5. Using your In-Ground Mount, place it in the center of your hole and onto the gravel, and level it as best you can at this point. If the In-Ground Mount is sitting below ground level, you can use more gravel to raise the height to a flush fit or plate resting above ground level (flush fit shown **FIGURE 4**).
6. With the In-Ground mount now set, begin to pour your concrete until the bore is filled. Smoothen out to your desired look and double check that the In-Ground is level. Wait 24hrs minimum for the concrete to cure.
7. Retrieve the Spigot from your umbrella. It will already be inserted into the mast, and place it on the In-Ground Mount. Using the supplied hardware that is packed with your umbrella, bolt the Spigot onto the In-Ground Mount (**FIGURE 4**). Once your Spigot is secure to the mount, begin to lift the Aurora onto the Spigot until you hear an audible "click" indicating your umbrella is secure.

INCLUDED IN-GROUND SPECIFIC MOUNTING HARDWARE

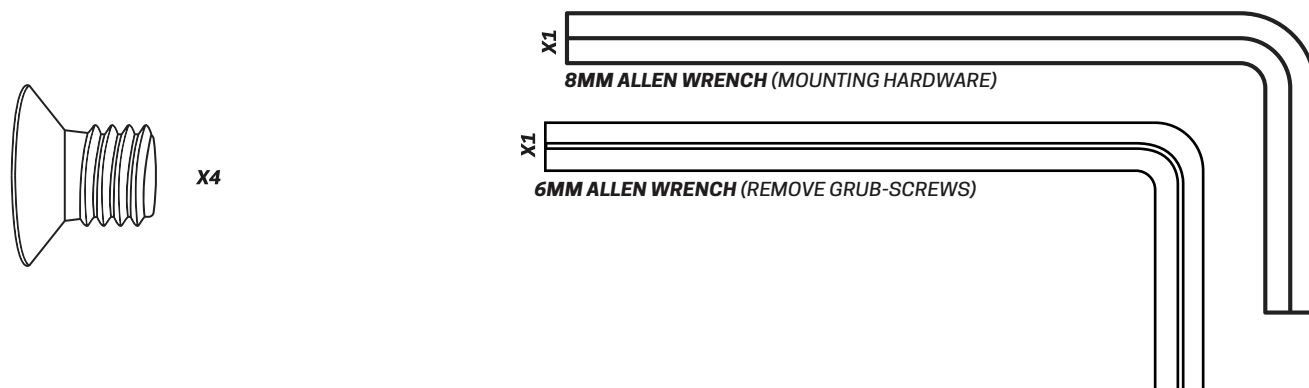

Remember the depth of the hole is more important than width, and it is much easier to make the hole larger at the time of installation than to try and re-stabilize the in-ground mount should it start to move at a later date.

FIGURE 1

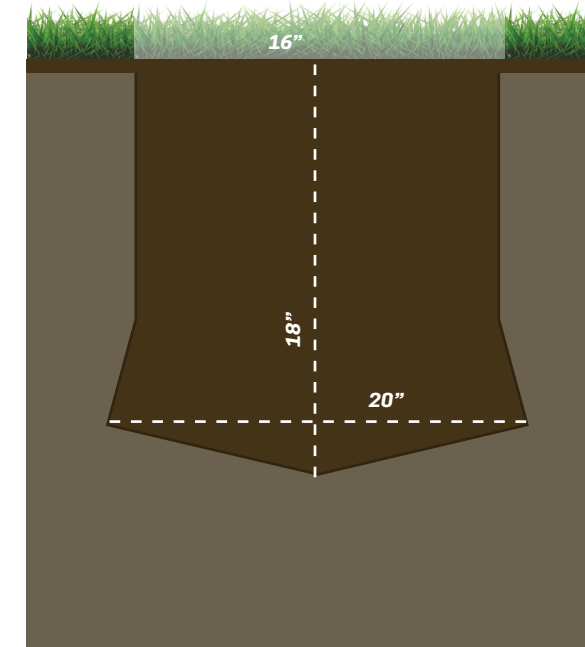

FIGURE 2

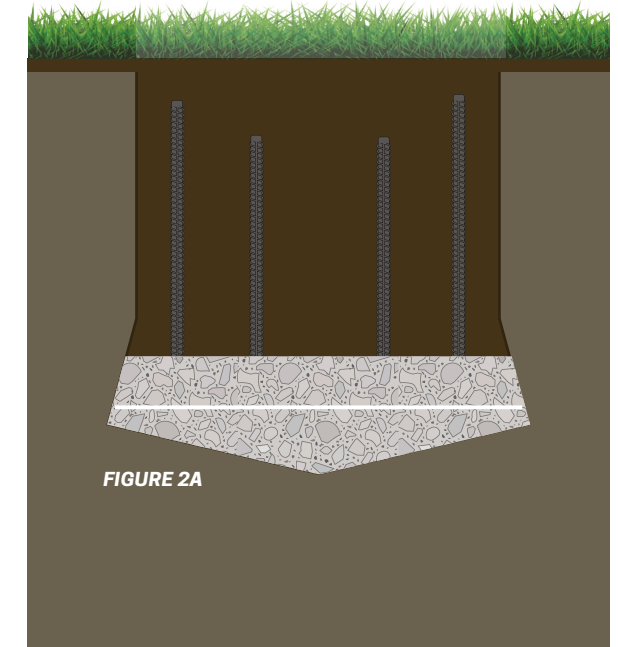

FIGURE 3

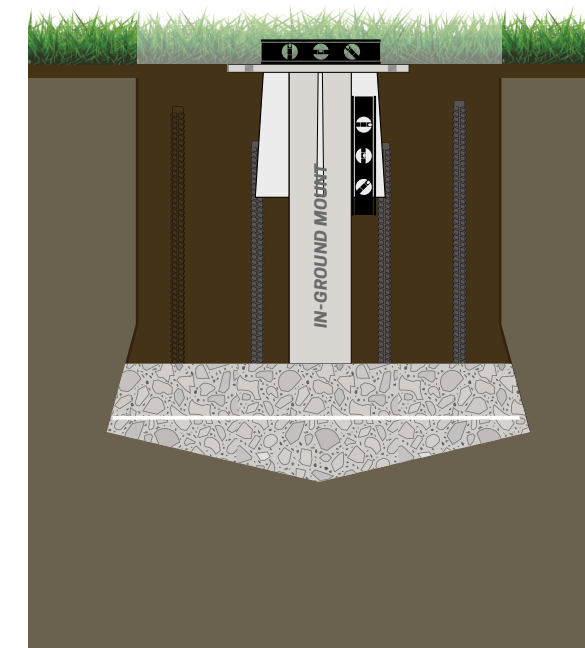
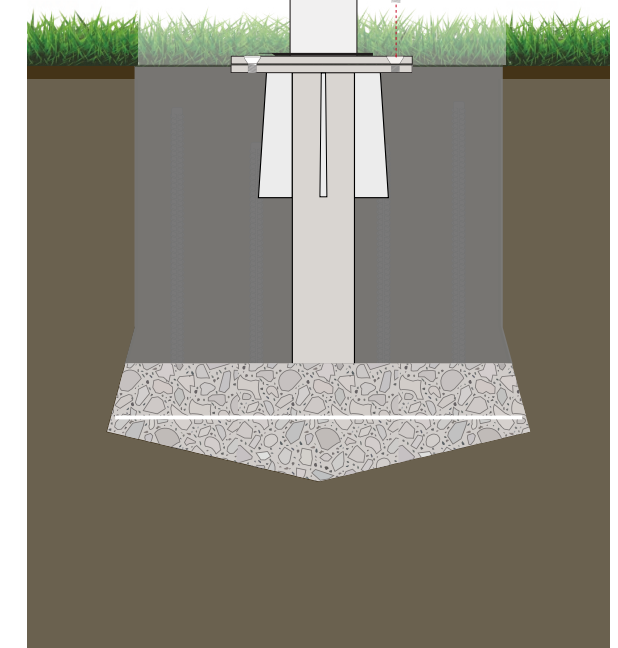

FIGURE 4



AURORA

DECK SURFACE INSTALLATION



GRUB-SCREWS ARE IN PLACE TO PROTECT THE THREADED HOLES ON BASES DURING SHIPPING AND STORAGE. THEY MUST BE REMOVED AND DISCARDED BEFORE THE INSTALLATION OF ANY UMBRELLA.

Your Aurora Cantilever comes with the Spigot already inserted in the mast of your umbrella. Once you have properly installed your Deck Plate, remove the Spigot from your umbrella and you can begin to mount your Spigot to the Deck Plate, and then the umbrella. (see **FIGURE 4**).

TOOLS & MATERIALS NEEDED

- Power Drill
 - 1/2" - 1" Open ended or Box Wrench
 - 1/2" - 1" Ratchet Wrench
 - Level
 - Tape Measure
 - Wood Brace Block - 2" x "Distance of your joists under the deck planks" (2" minimum)
 - (8) "Big Timber #9" Coarse Wood Screws
 - (4) 1/2" x 4" Socket Countersunk Flat Head Screws
 - (4) 1/2" Hex Nuts
 - (4) 1.5" OD (outside diameter) Fender Washers / 1/2" ID (inside diameter)
1. Unpack your Deck Plate and place into the position you plan on installing your cantilever umbrella. Evenly place across wood planks (**FIGURE 1**) and be sure you are between deck joists. Use your drill with a 1/2" drill bit, place your foot with a good amount your weight on the deck plate (**FIGURE 1-A**), and drill out the outer holes (**FIGURE 1 :magenta:**) through your mounting planks.
 2. With the holes drilled, remove your Deck Plate, and begin to remove the adjacent wood planks. Enough space for a visual of the deck joists (**FIGURE 1**).
 3. Measure the width between your joist and cut your wooden brace block to size (**FIGURE 2**). Using "Big Timber #9" or another generic outdoor wood screw, begin to secure the brace block into place against the joists and firmly up against the mounting wood planks (**FIGURE 2-A :magenta:**).
 4. Now that the brace block is secure, move your attention to the four holes drilled for the Deck Plate mounting. Using the same drill bit to initially set the pattern placement, drill clean through the brace block (**FIGURE 3**).
 5. With clear holes drilled through the planks and the brace block, place the Deck Plate back in place, and drop in your 1/2" x 4" (adjust to specific depth) countersunk flat head screws. Place the fender washer and nut on the underside and hand tighten.
 6. With the bolts hand tight, use your box or open wrench to hold the nut on the underside in place, and torque down firmly using the ratchet on the topside (**FIGURE 4**). Once the Deck Plate is firmly secure, replace the wooden planks you have removed in the beginning of the installation.
 7. Retrieve the Spigot from your umbrella. It will already be inserted into the mast. Place the Spigot on the Deck Plate lining up the inner four bolts. Using the supplied hardware that is packed with your umbrella, bolt the Spigot onto the Deck Plate (**FIGURE 5**). Once your Spigot is secure to the Deck Plate, begin to lift the Aurora onto the Spigot until you hear an audible "click" indicating your umbrella is secure.

INCLUDED DECK PLATE SPECIFIC MOUNTING HARDWARE

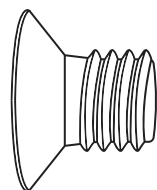

X4

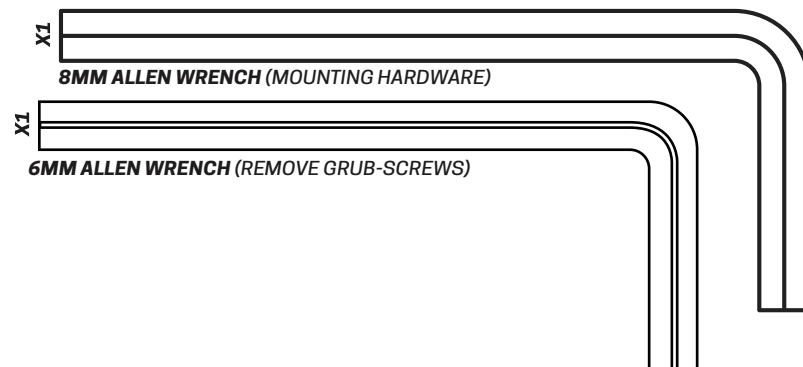

FIGURE 1

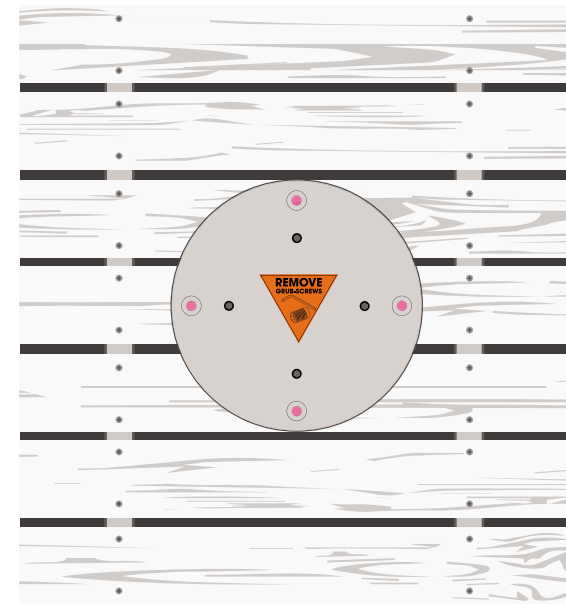

FIGURE 1-A

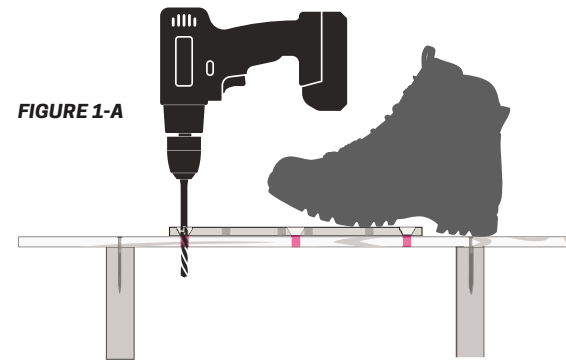

FIGURE 2

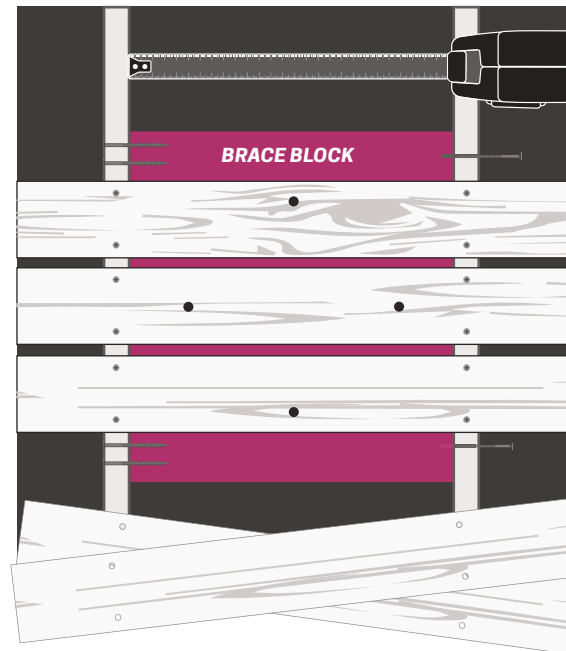

FIGURE 2-A

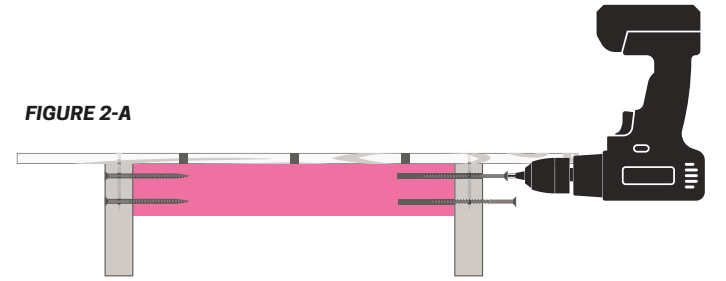

FIGURE 3

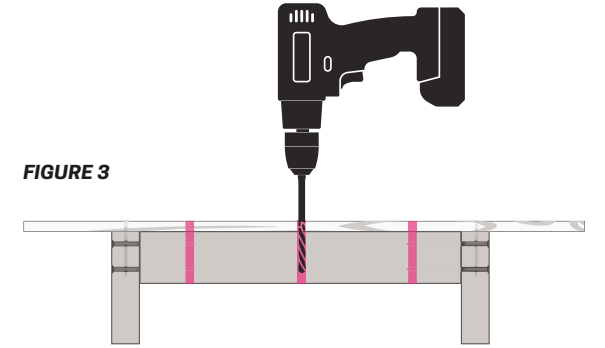

FIGURE 4

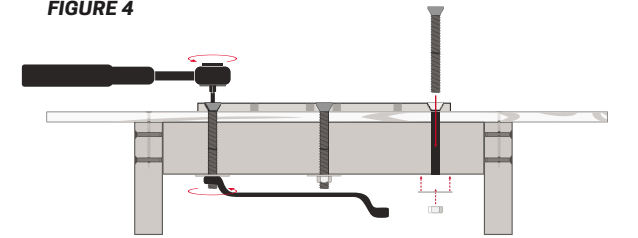
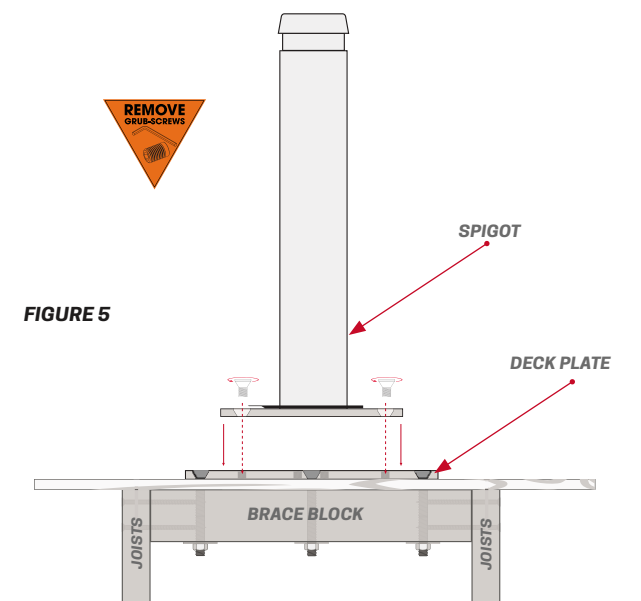

FIGURE 5



AURORA

CONCRETE SURFACE INSTALLATION



GRUB-SCREWS ARE IN PLACE TO PROTECT THE THREADED HOLES ON BASES DURING SHIPPING AND STORAGE. THEY MUST BE REMOVED AND DISCARDED BEFORE THE INSTALLATION OF ANY UMBRELLA.

Your Aurora Cantilever comes with the Spigot already inserted in the mast of your umbrella. Once you have properly installed your Deck Plate, remove the Spigot from your umbrella and you can begin to mount your Spigot to the Deck Plate, and then the umbrella. (see **FIGURE 4**).

IMPORTANT: Minimum recommended anchored depth should be no less than 3". We highly recommend there being at least a depth of 3.5" on any concrete or solid surface to anchor your umbrella into.

TOOLS & MATERIALS NEEDED

- (x4) 1/2" x 3 3/4" Concrete Wedge Bolts (Longer can be used) - Min. length of 3" if applicable.
- Marker/Paint to mark drill point on surface
- Level
- 1/2" Open ended or box wrench (Torque Wrench is optimal)
- Hammer Drill / 1/2" x 4" Carbide mason hammer drill bit 4" +
- 1/2" Open ended or box wrench.
- Hammer
- Can of Air / Air Compressor

1. Unpack your Deck Plate and place onto the position you plan on installing your cantilever umbrella. Using a marker or spray paint, mark through the bolting pattern (**FIGURE 1 :magenta:**) onto the concrete.
2. Now that your marks are in place, measure the depth you intend to drill on the drill bit and add at least 1/2" to the depth and mark with a piece of masking tape around the drill bit (min. 3" + 1/2"). (**FIGURE 2**)
TIP: BE SURE TO DRILL 1/2" DEEPER THAN THE ANCHOR AND REMOVE DUST FROM THE HOLE THAT WOULD PREVENT THE ANCHOR FROM COMPLETELY DROPPING IN.
3. Set your Deck Plate back in place over the holes you have just drilled. Drop your wedge or sleeve anchors in, and if needed, use a hammer to pound the anchors fully down and into the Deck Plate. The washers should nestle nicely into the edge of the countersunk hole, or overlap the countersunk hole. Either is perfectly fine and will not compromise the installation (**FIGURE 3**).
4. Using your 1/2" wrench or a drill, torque down the anchors to 55 lbs. (74Nm) of torque wrench is available (**FIGURE 3**).
5. Now that your Deck Plate is in place and secured, double check that the grub-screws are removed from the inner pattern, retrieve your Spigot from the mast of your cantilever and set onto the Deck Plate in place over the threaded holes.
6. Using the supplied hardware that is packed with your umbrella, bolt the Spigot onto the Deck Plate (**FIGURE 4**). Once your Spigot is secure to the Deck Plate, begin to lift the Aurora onto the Spigot until you hear an audible "click" indicating your umbrella is secure.

INCLUDED DECK PLATE SPECIFIC MOUNTING HARDWARE

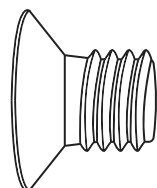

X4

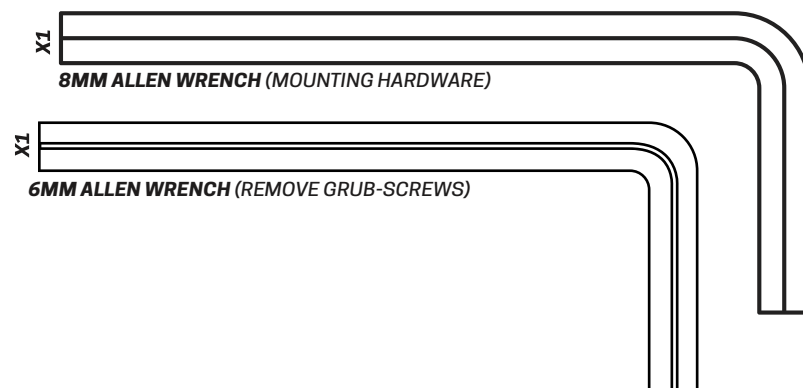

IMPORTANT: You will need at least 3 1/2" of solid depth for a sufficient installation. Any shallower than 3" the integrity of the install may be compromised causing catastrophic failure to your surface, the umbrella and surrounding property. Always consult a professional before installing.

FIGURE 1

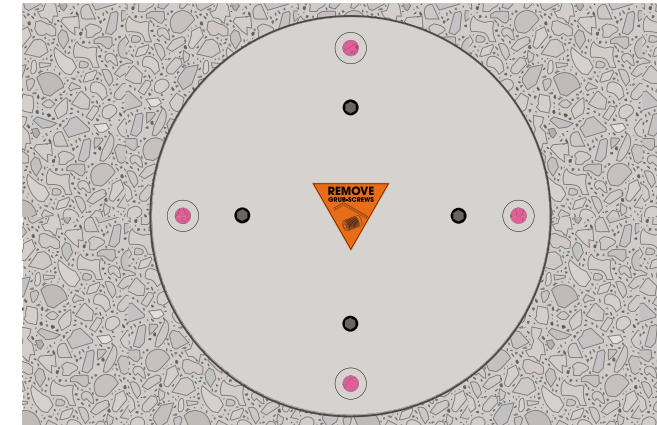

Put the Deckplate in place where you intend to mount your umbrella and mark where you need to drill into the concrete.

FIGURE 2

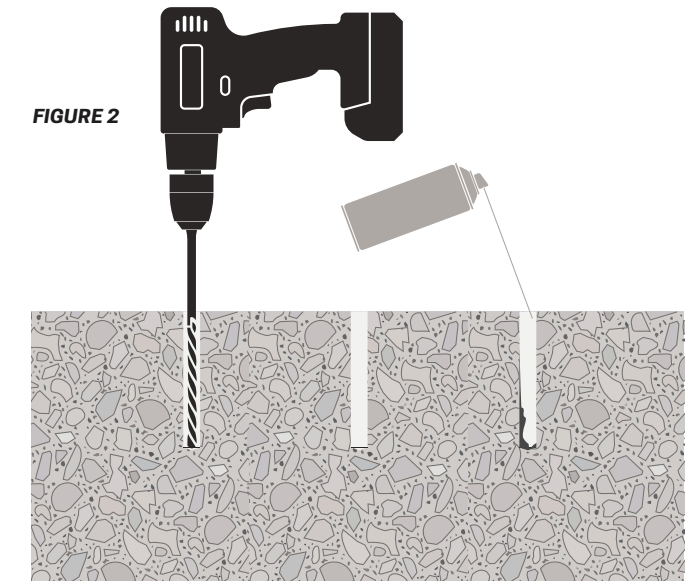

Drill your markings that you've marked by wrapping tape on your drill bit. (**See TIP**)

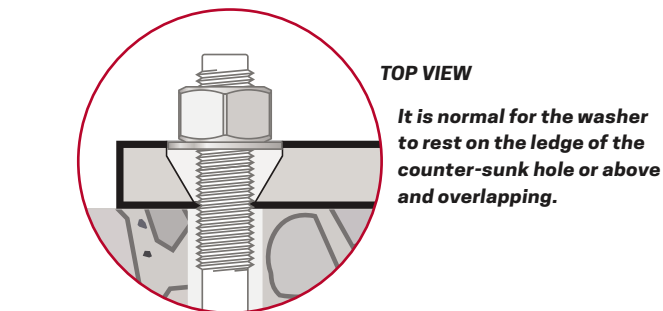
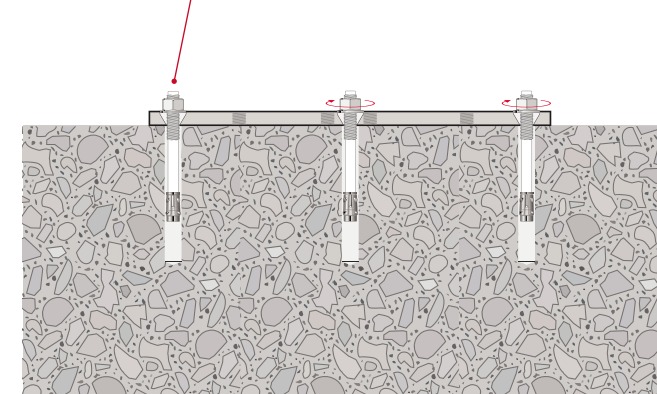
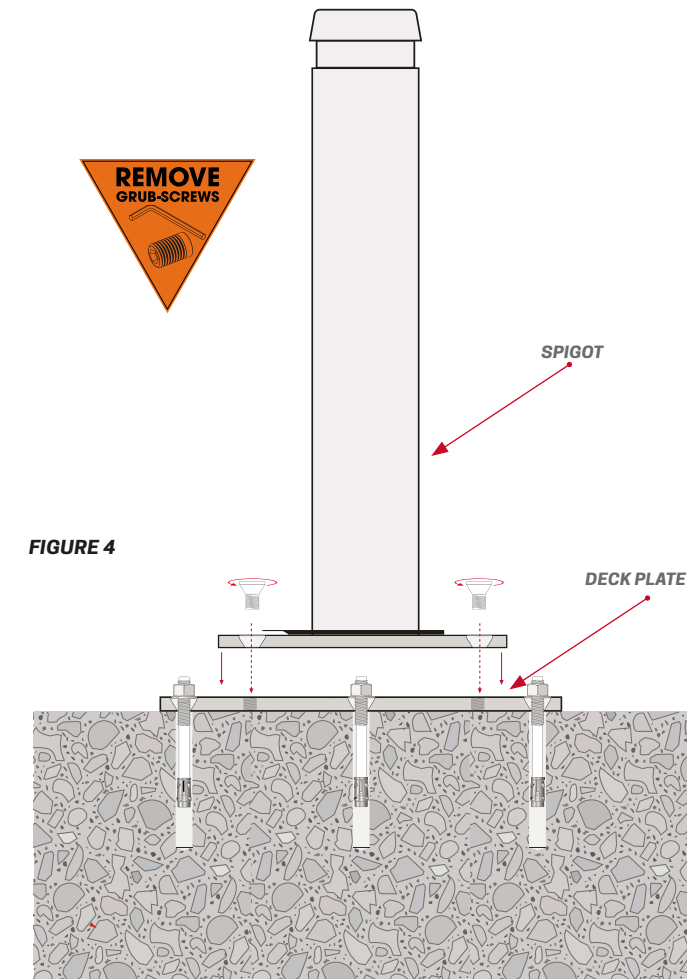

FIGURE 3



Drop your wedge anchors in (hammer in if-needed), and torque down all four bolts.

FIGURE 4



Mount your Spigot to the inner four threaded holes exposed by removing the grub-screws.



AURORA

40G+36G ROUND GALVANIZED PLATE STACK

Your Aurora Cantilever comes with the Spigot already inserted in the mast of your umbrella. Once you have properly stacked your G-Plate, remove the Spigot from your umbrella and you can begin to mount your Spigot to the plate stack, and then the umbrella. (see **FIGURE 4**).



GRUB-SCREWS ARE IN PLACE TO PROTECT THE THREADED HOLES ON BASES DURING SHIPPING AND STORAGE. THEY MUST BE REMOVED AND DISCARDED BEFORE THE INSTALLATION OF ANY UMBRELLA.

- Once your 40G-Plate is unpacked, move into the desired location you will be mounting the umbrella. Once in place immediately remove and discard ALL Grub-Screws from the G-Plate (**FIGURE 1**).
- Locate your pair of Guide Pins and hand tighten into a pair of parallel threaded holes into the 40G-Plate you have set into place and is designated as your bottom plate (**FIGURE 1-A**).
- Begin to unpack your 36G stacking plate. Using a half of the white packing foam, place on the edge of the bottom plate already in place and set down your plate (**FIGURE 2A**). This will help prevent any pinching of your fingers or injury.
- TWO PERSON JOB:** Lift your 36G-Plate (**FIGURE 2**), and slowly stack the plate with the “naked” non-threaded holes over the Guide Pins. If the plate does not pass through and set down, please check to be sure you have rotated the plate to line up the “naked” holes with the Guide Pins.
- Once all three plates are stacked, and over the Guide Pins, retrieve and remove the Spigot from the mast of your Aurora umbrella. Place the Spigot over the Guide Pins (**FIGURE 3**) then remove the Guide Pins and you will have a clear visible path to the bottom plate’s threaded holes.
- With your Spigot in place on G-Plate stack lined up to the outer four bolts, use the supplied hardware that is packed with your umbrella and bolt the Spigot onto the G-Plate stack threading down into the bottom plate (**FIGURE 4**). Once your Spigot is secure to the G-Plate stack, begin to lift the Aurora onto the Spigot until you hear an audible “click” indicating your umbrella is secure.

INCLUDED G-PLATE DOUBLE STACK SPECIFIC MOUNTING HARDWARE

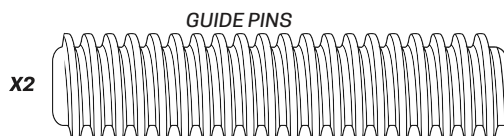
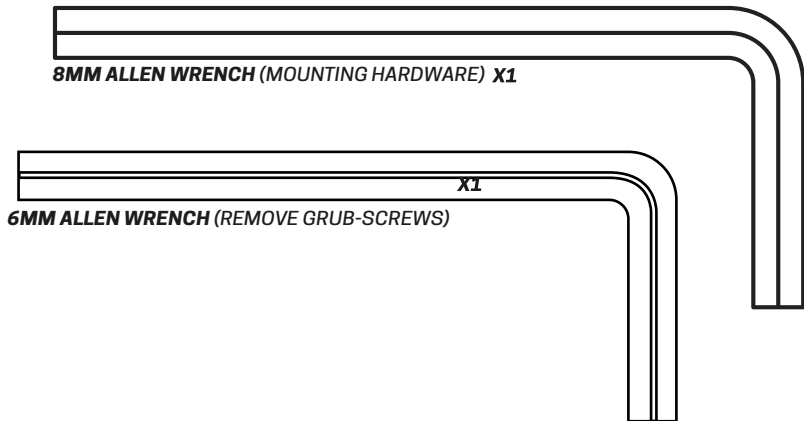
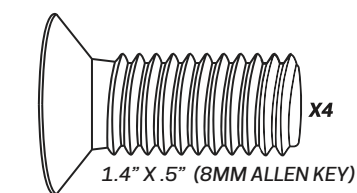

FIGURE 1

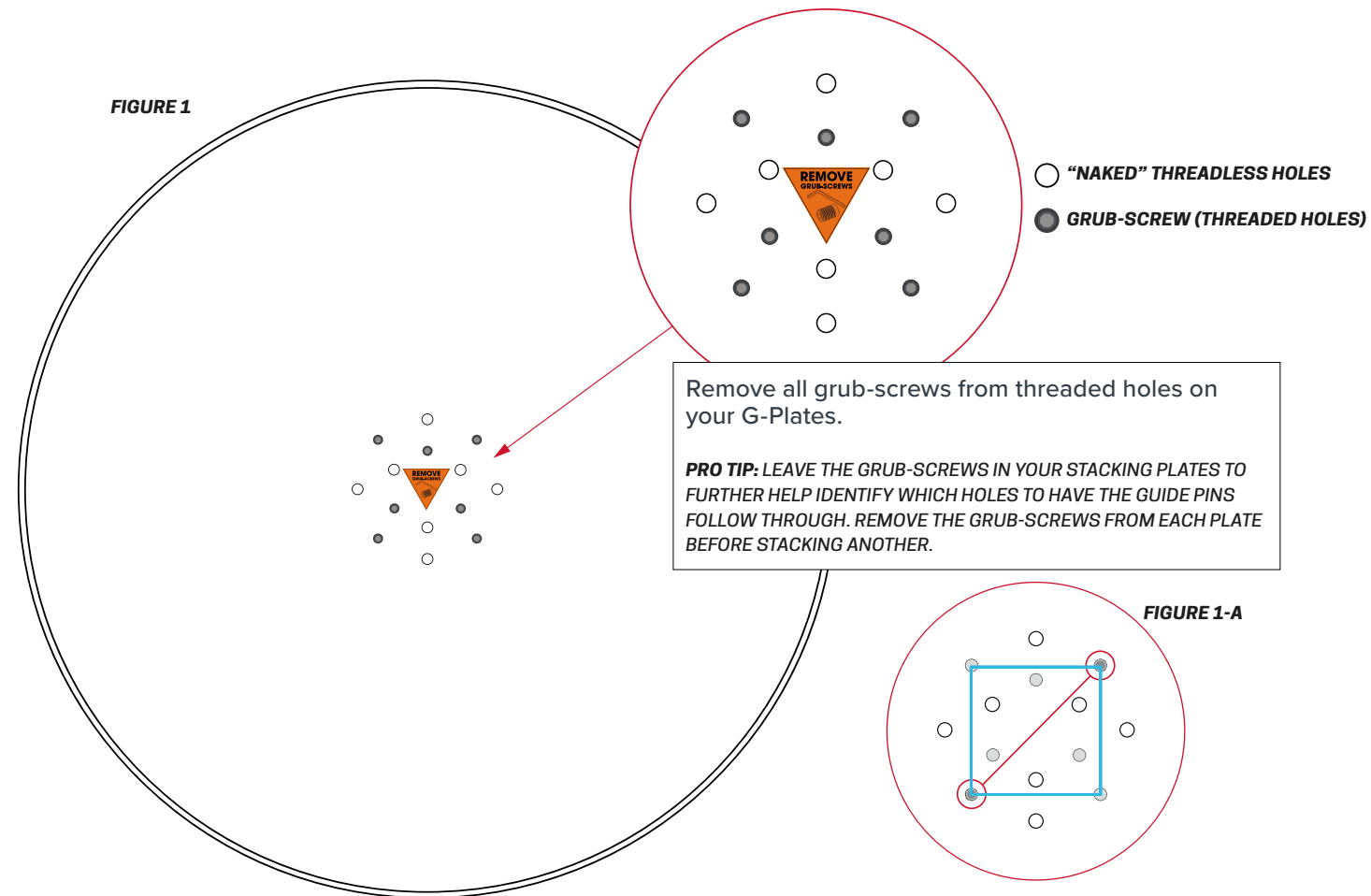
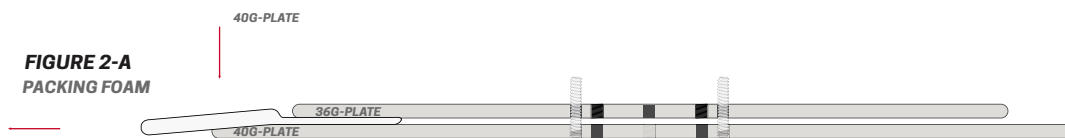

FIGURE 1-A

FIGURE 2



Once your spigot is in place and on the Guide Pins, begin to remove them from the stack.

This will give a clear visible path to the bottom plate’s threaded holes.

FIGURE 3

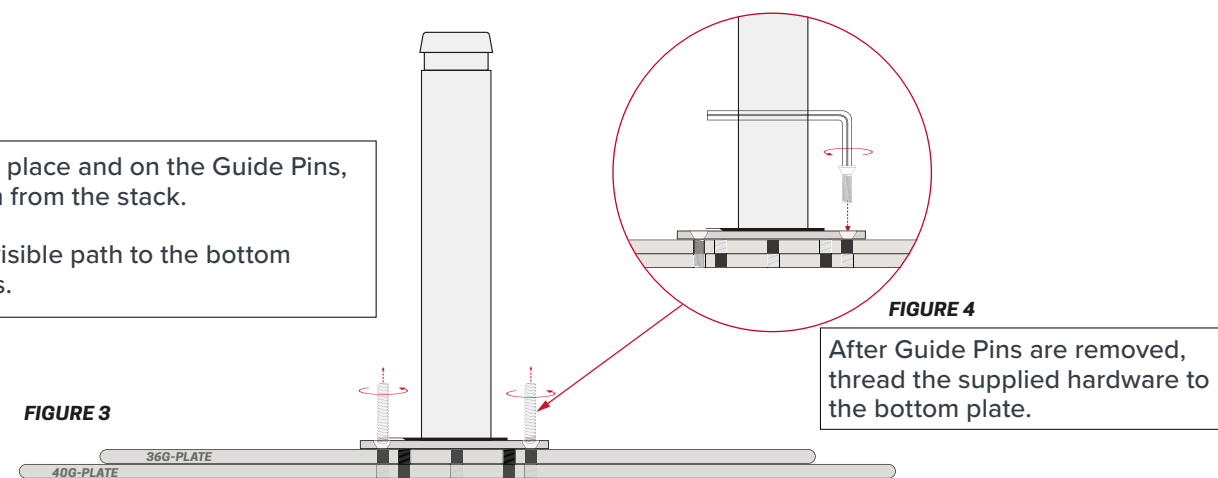

FIGURE 4

AURORA

36Gx2 SQUARE GALVANIZED PLATE STACK



GRUB-SCREWS ARE IN PLACE TO PROTECT THE THREADED HOLES ON BASES DURING SHIPPING AND STORAGE. THEY MUST BE REMOVED AND DISCARDED BEFORE THE INSTALLATION OF ANY UMBRELLA.

Your Aurora Cantilever comes with the Spigot already inserted in the mast of your umbrella. Once you have properly stacked your G-Plate, remove the Spigot from your umbrella and you can begin to mount your Spigot to the plate stack, and then the umbrella. (see **FIGURE 4**).

- Once your 36G-Plate ("Bottom Plate") is unpacked, move into the desired location you will be mounting the umbrella. Once in place immediately remove and discard ALL Grub-Screws from the G-Plate (**FIGURE 1**).

NOTE: If you are installing Caster Wheels (+W), do-so before stacking your "Top Plates" (If you choose to use wheels after you've created a stack, you will have to remove the top plate to install the wheels). Once your wheels are installed, be sure to lock them in place while completing your stack.
- Locate your pair of Guide Pins and hand tighten into a pair of parallel threaded holes into the 36G-SQ ("Bottom Plate") you have set into place (**FIGURE 1-A**).
- Begin to unpack your 36G-SQ "Top Plate". Using a half of the white packing foam, place on the edge of the bottom plate already in place and set down your plate (**FIGURE 2A**). This will help prevent any pinching of your fingers or injury.
- TWO PERSON JOB:** Lift your second 36G-SQ "Top Plates" (**FIGURE 2**), and slowly stack the plate over the Guide Pins. Repeat for your third plate to complete the stack.
- Once both plates are stacked, and over the Guide Pins, retrieve and remove the Spigot from the mast of your Aurora umbrella. Place the Spigot over the Guide Pins (**FIGURE 3**) then remove the Guide Pins and you will have a clear visible path to the bottom plate's threaded holes.
- With your Spigot in place on G-Plate stack lined up to the outer four bolts, use the supplied hardware that is packed with your umbrella and bolt the Spigot onto the G-Plate stack threading down into the bottom plate (**FIGURE 4**). Once your Spigot is secure to the G-Plate stack, begin to lift the Aurora onto the Spigot until you hear an audible "click" indicating your umbrella is secure.

+W (WHEEL OPTION HARDWARE)

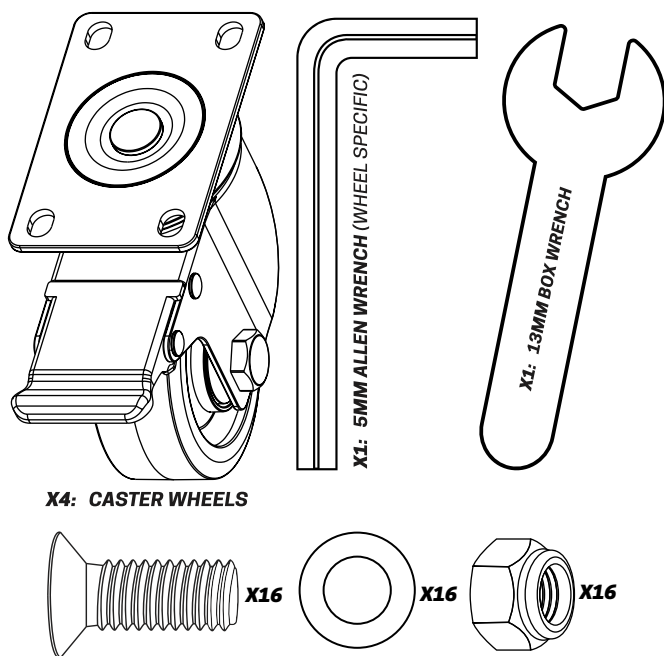

INCLUDED G-PLATE DOUBLE STACK SPECIFIC MOUNTING HARDWARE

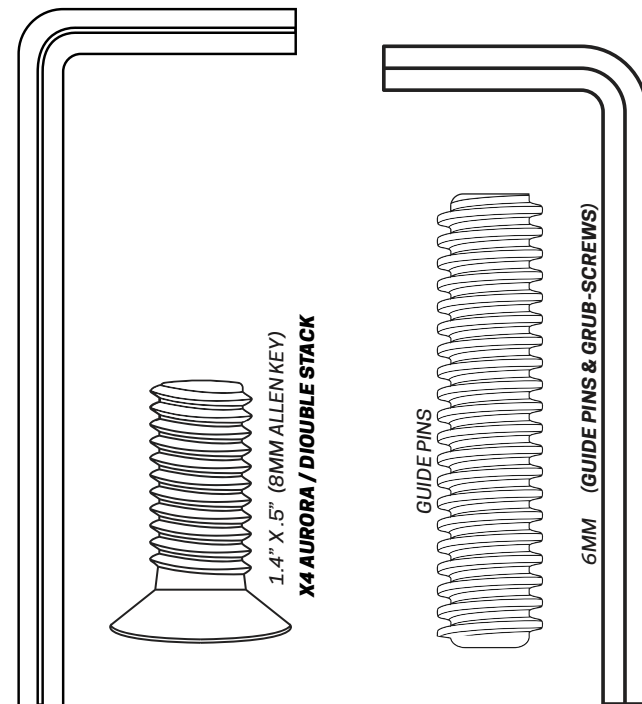
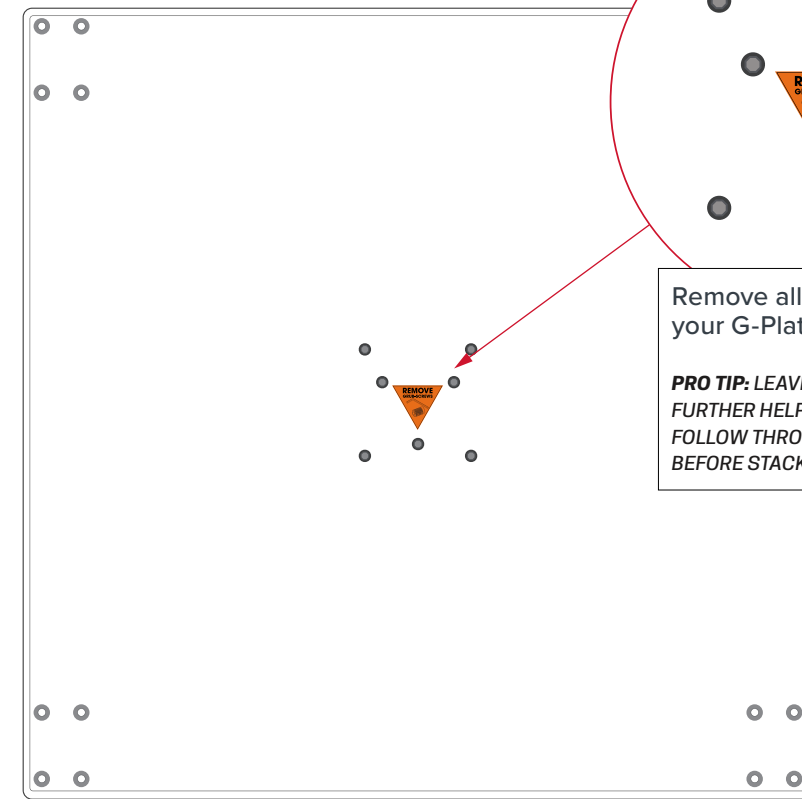

FIGURE 1 - (BOTTOM PLATE / "THREADED HOLES")



● GRUB-SCREW (THREADED HOLES)

Remove all grub-screws from threaded holes on your G-Plates.

PRO TIP: LEAVE THE GRUB-SCREWS IN YOUR STACKING PLATES TO FURTHER HELP IDENTIFY WHICH HOLES TO HAVE THE GUIDE PINS FOLLOW THROUGH. REMOVE THE GRUB-SCREWS FROM EACH PLATE BEFORE STACKING ANOTHER.

FIGURE 1-A

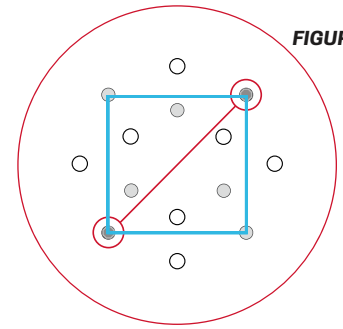

FIGURE 2 - (STACKING PLATES / "TOP PLATE")

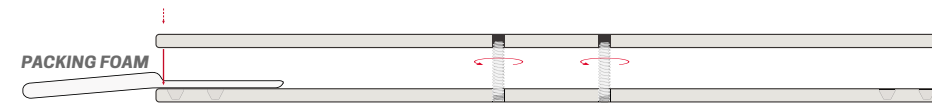
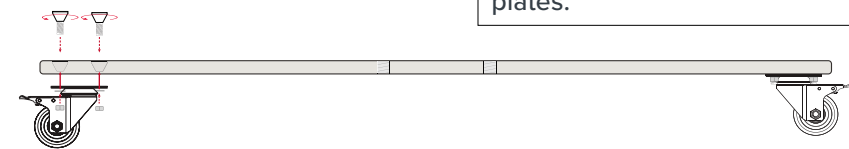

FIGURE 2-A - (INSTALLING CASTER WHEELS)



If installing Caster Wheels, you must install to your bottom 36G plate before stacking other plates. Be sure to lock your wheels before stacking other plates.

FIGURE 3

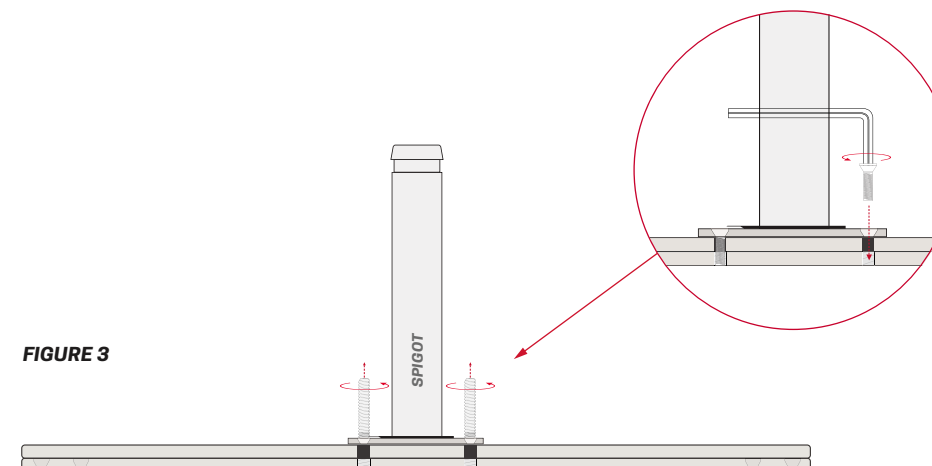

FIGURE 4

After Guide Pins are removed, thread the supplied hardware to the bottom plate.

AURORA

ARU-480 ROLLING BASE



GRUB-SCREWS ARE IN PLACE TO PROTECT THE THREADED HOLES ON BASES DURING SHIPPING AND STORAGE. THEY MUST BE REMOVED AND DISCARDED BEFORE THE INSTALLATION OF ANY UMBRELLA.

Your Aurora comes with the Spigot (35) already inserted in the mast of your umbrella. Once you have properly leveled your base (if adjustable feet used) or have installed the caster wheels and have them in the locked position, you can begin to mount your Spigot (35) and then umbrella. (see **FIGURE 1**).

IMPORTANT: Your umbrella mounting hardware, wheels (hardware) and adjustable feet are packed within the base. Remove the lid to locate and retrieve your hardware and accessories. Proceed to remove the grub-screws from the mounting plate on the ARU-480.

TOOLS & MATERIALS NEEDED

- A trusted level (if adjustable feet are chosen)
- Twelve (12) Concrete Pavers (recommended weight 35 lbs. +) 2" x 16" - Most pavers have a tolerance and may be smaller. The weight is most important. Minimum weight per quadrant 100-110lbs.
- 1/2" Crescent or box wrench

1. Once you have unpacked your ARU-480, remove the lid, locate and retrieve your mounting hardware, wheels (hardware) and adjustable feet. Choose which you would like to use and install before weighing down with pavers and/or weights.
2. After you have installed the wheels or feet, pavers should be placed in the base corner towards the center first (**FIGURE 1**), under the mounting plate. Repeat in each quadrant until the base is full with Twelve (12) appropriately weighted pavers.
3. After your base is sufficiently weighed down, place the lid back onto the base (**FIGURE 2**), lock your wheels if installed, and retrieve your Spigot (35) from the mast of the Aurora
4. Mount your Spigot (35) to the ECU-480 with the included mounting hardware on the outer threaded pattern (**FIGURE 3A**).
5. With your Spigot in place and on 480 Mounting Plate, use the supplied hardware that is packed with your umbrella and bolt the Spigot onto the plate threading down to only the plate (**FIGURE 3**). Once your Spigot is threaded down, begin to lift the Aurora onto the Spigot until you hear an audible "click" indicating your umbrella is secure.

INCLUDED ARU-480 SPECIFIC MOUNTING HARDWARE

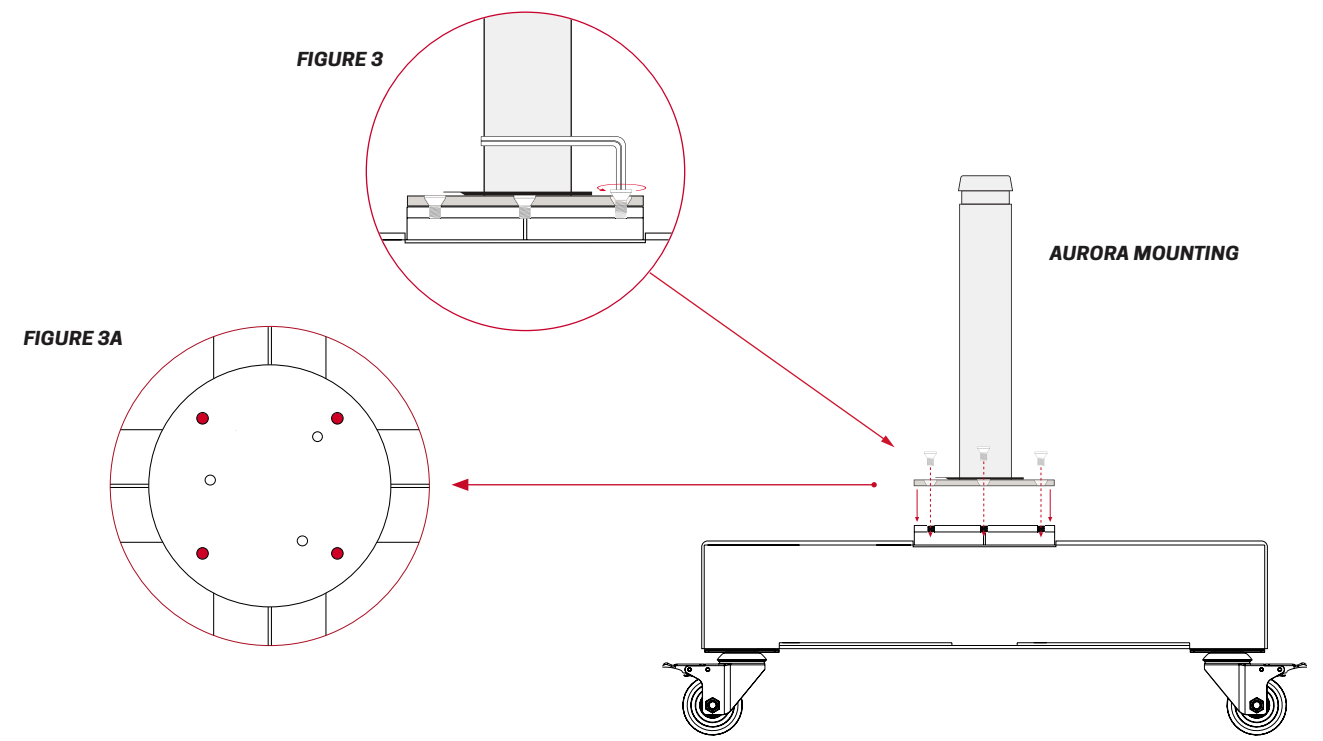
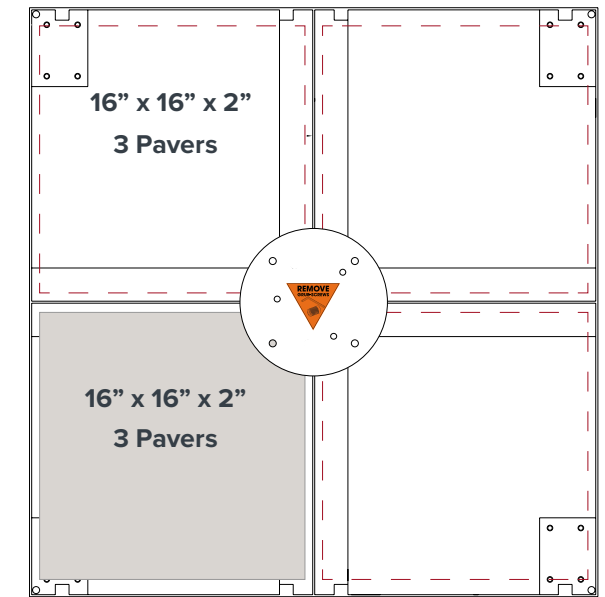
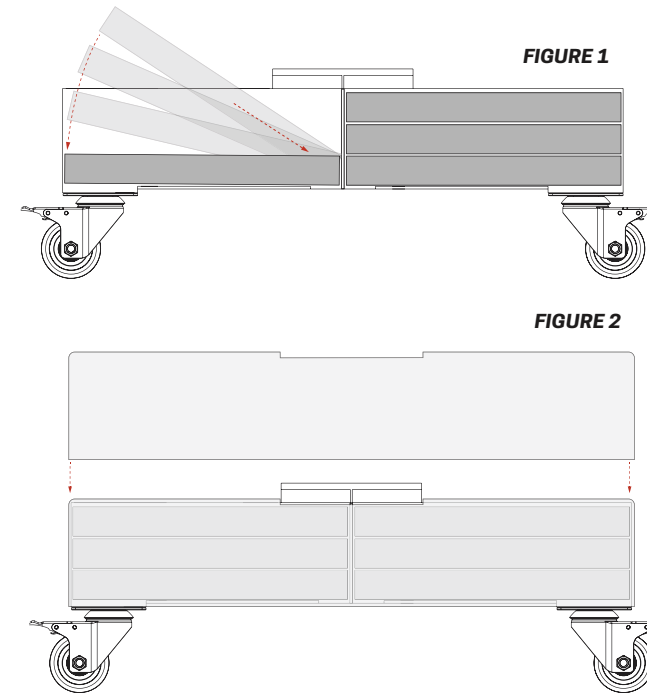
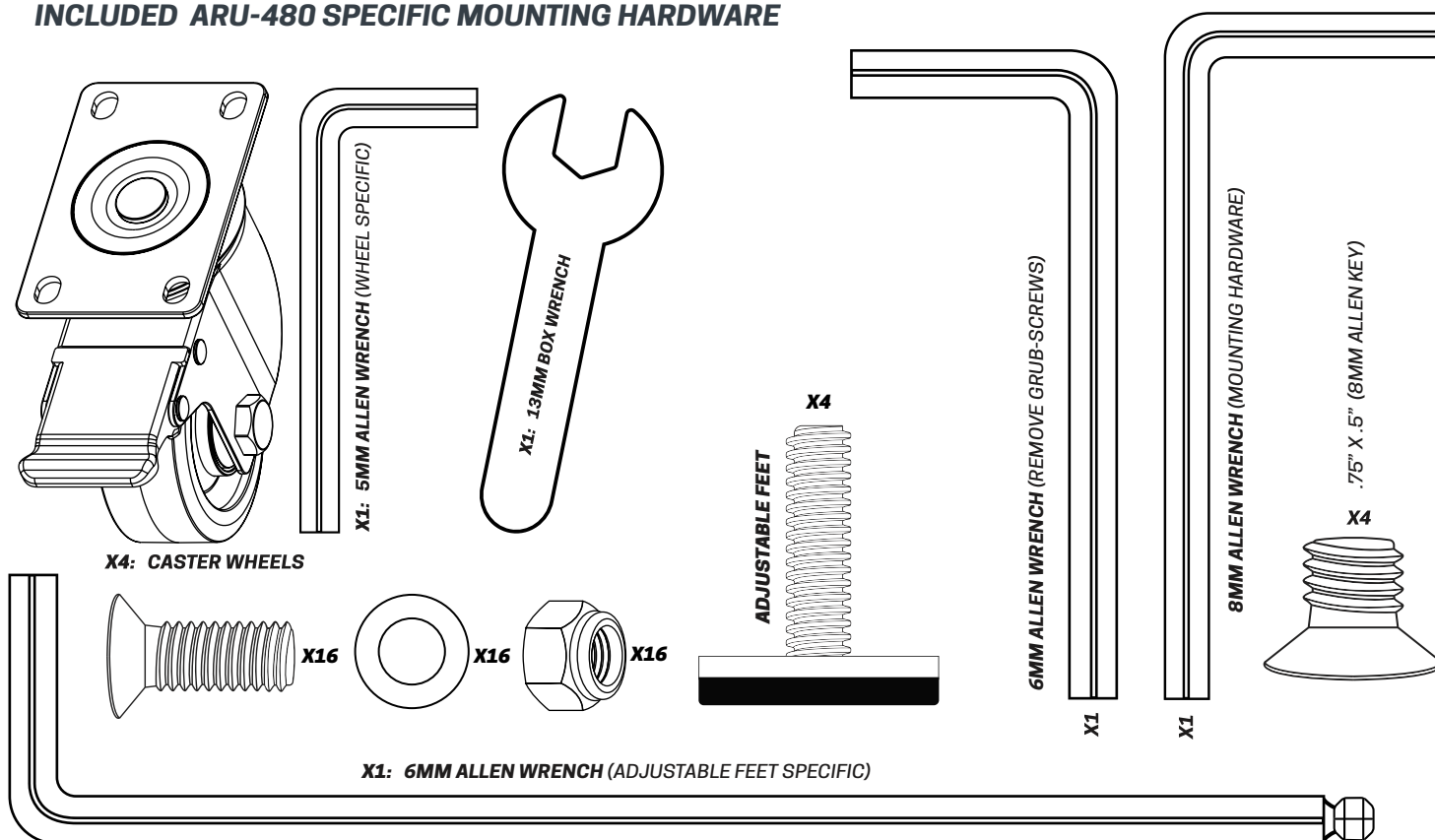

AURORA

CROSS BASE

Your Aurora comes with the Spigot (35) already inserted in the mast of your umbrella. Once you have properly leveled your base (if adjustable feet used) or have installed the caster wheels and have them in the locked position, you can begin to mount your Spigot (35) and then umbrella. (see **FIGURE 1**).

IMPORTANT: Your Cross Base is shipped disassembled.

TOOLS & MATERIALS NEEDED

- A trusted level (if adjustable feet are chosen)
- Eight (8) Concrete Pavers (recommended weight 35 lbs. +) 2" x 16" - Most pavers have a tolerance and may be smaller. The weight is most important. Minimum weight per quadrant 100-110lbs.
- Rubber Mallet

Once you have decided on the location of the Aurora umbrella, make sure you have an area of at least 40" in diameter for the base to rest, then place your assembled Cross Base into position. Locate the four threaded holes on the legs at the crossing point. (This pattern can be identified on the below drawing).

1. Once your Cross Base is fully unpacked, begin to attach the end plates to the cross bars using the supplied hardware.
2. Lay the (A) cross-bar down first (this is the bar with the notched center).
3. Lay the (B) cross-bar across the center of the notch of the (A) cross-bar, and use a rubber mallet if necessary to securely fit full down into the notch.
4. Retrieve and remove the Spigot from the mast of your Aurora umbrella. Place the Spigot over the four hole bolt pattern (**FIGURE 3**) then using the supplied hardware that came with your umbrella, bolt your Spigot down to the Cross Base. This will effectively lock the cross bars together creating a solid footing for your Aurora Cantilever.
5. Now that your Cross Base is full assembled with the Spigot mounted, you can begin to place the 16" x 16" x 2" pavers into the open quadrants. Be sure to use the maximum (if cover is being used See next page) of two pavers per quadrant (8 total).
6. With your Cross Base properly assembled, weighted and the Spigot is secure, you can begin to lift the Aurora onto the Spigot until you hear an audible "click" indicating your umbrella is secure.

NOTE: You can stack a maximum of 12 pavers (3 per quadrant) within your Cross Base to create a heavier footprint. Total minimum (8 pavers) recommended weight should be no less than 280 lbs. If 12 pavers are used, you cannot use the Cross Base Cover (+C).

INCLUDED XB MODULAR BASE SPECIFIC MOUNTING HARDWARE

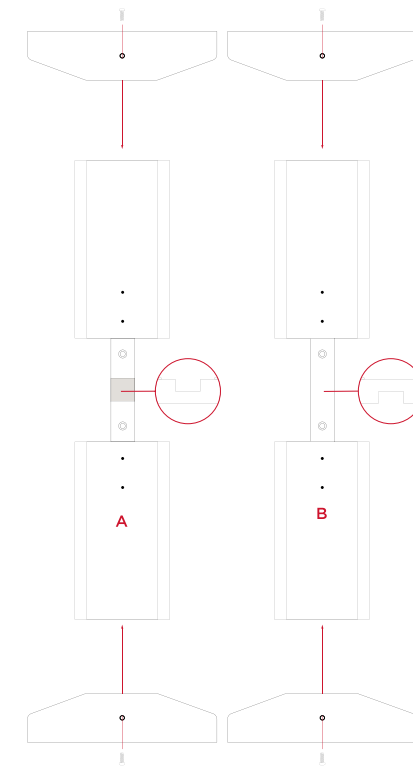
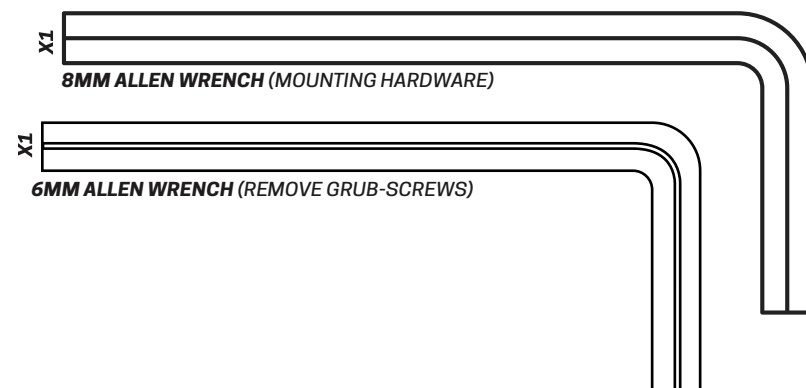
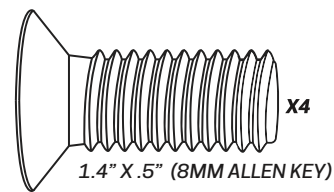

FIGURE 1

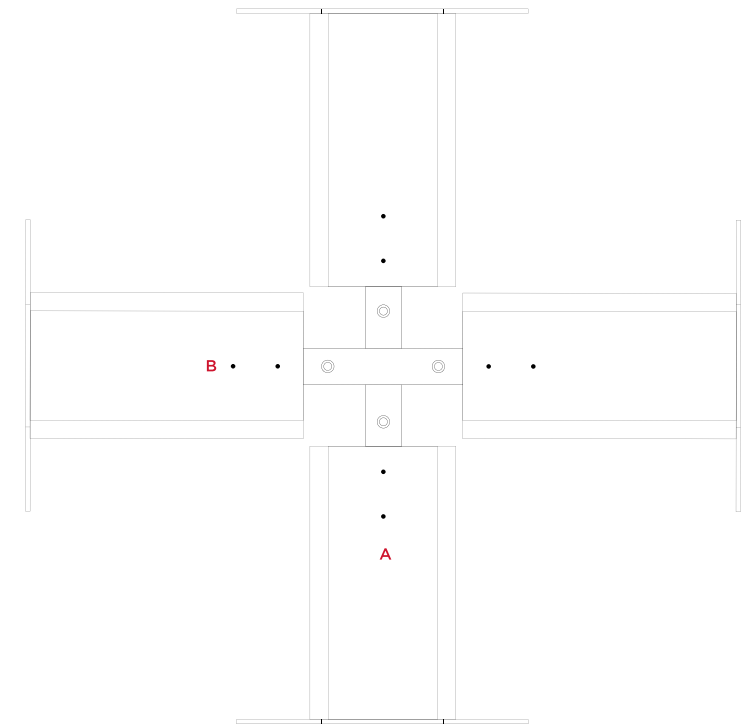

FIGURE 2

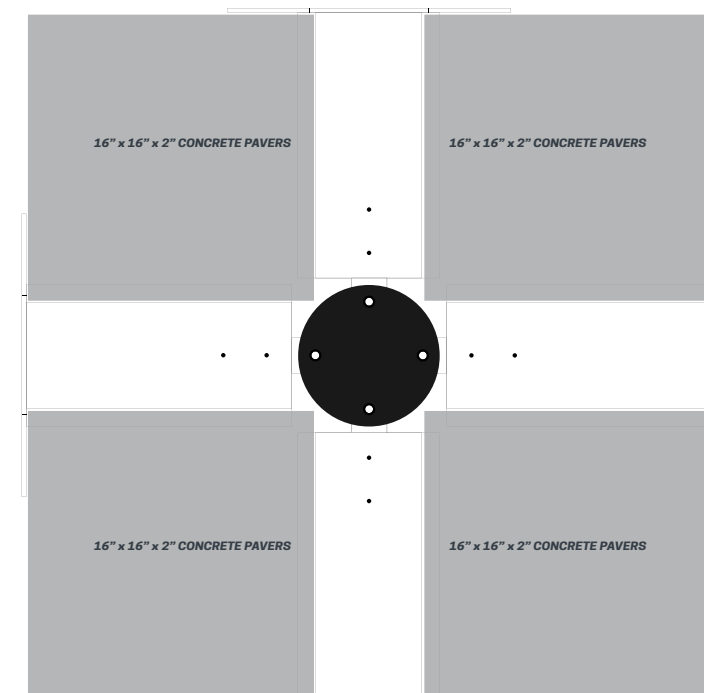

FIGURE 3

AURORA

CROSS BASE COVER (+C)

The Aurora Cross Base Cover ships flat and is easy to assemble. It is specifically designed for the Cross Base with 8 pavers and seamlessly fits over the Cross Base creating a more aesthetically pleasing look.

IMPORTANT: Avoid using a hammer or other hard materials when assembling. Some force may be required to lock pieces into place. We suggest firm pressure or a rubber mallet to assure all tabs are locked in and secured.

Once you have decided on the location of the Aurora umbrella, make sure you have an area of at least 40" in diameter for the base to rest, then place your assembled Cross Base into position. Locate the four threaded holes on the legs at the crossing point. (This pattern can be identified on the below drawing).

1. Clear out a space on the floor or flat surface. Lay Flat Top Panel (A) face down. Peel off the red strips from the 3M double-sided tape on the underside of the Flat Top Panel (FIGURE 1).
2. Place the four corner extrusions (C1-4) underneath the panel by lining up the guide hole (FIGURE 1-A).
3. Pick up a Long Side Panel (B1-4) and line up the locking window and hook slot in the corner extrusion (FIGURE 2). When the side panel is in place, you'll notice the window slotted with the tab from the corner extrusion (FIGURE 2-A).

NOTE: There is a rolled edge on the side panels. Make sure this is facing the top panel and sits flush against the bead of dampening tape. You may need to apply gentle force these panels to lock in place. We suggest using a rubber mallet or a towel and a block of wood or a material in equal hardness.

4. Repeat this process on the remaining three sides. When complete, your cover should look like (FIGURE 3).

NOTE: Before turning over and placing on your Cross Base, be sure to double check the corner extrusions (C1-4) and that all locking tabs are still in place and all side panels (B1-4) are flush and level against the top panel (A).

HARDWARE

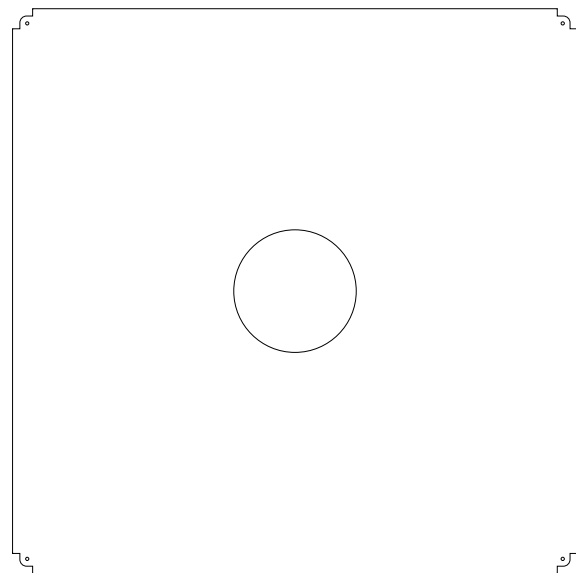

1 x FLAT TOP PANEL WITH SPIGOT HOLE (A)



4 x LONG SIDE PANELS (B)

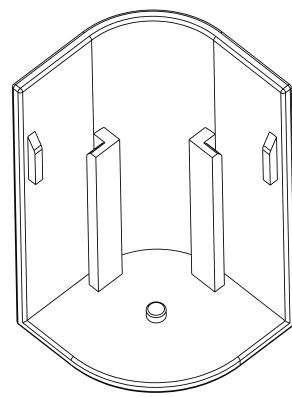

4 x CORNER EXTRUSIONS (C)

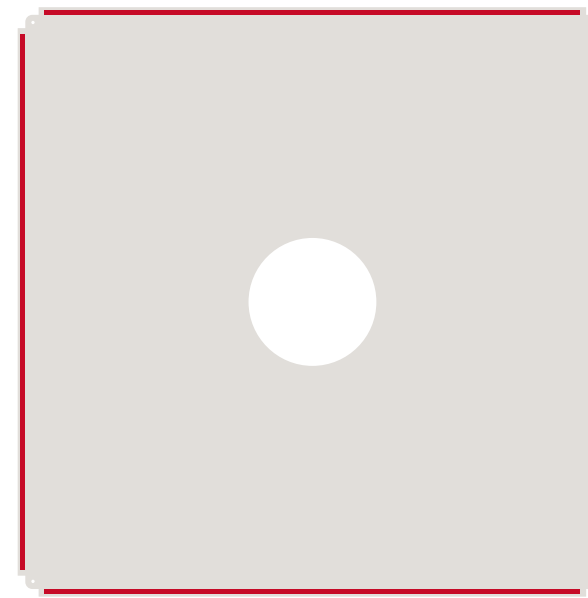

FIGURE 1

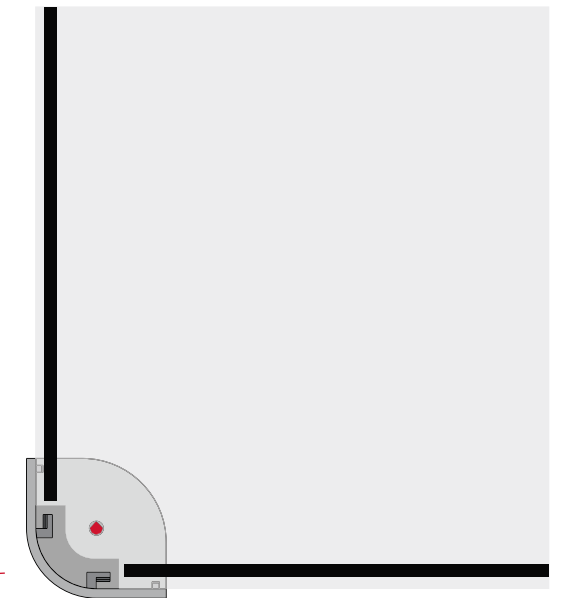

FIGURE 1-A

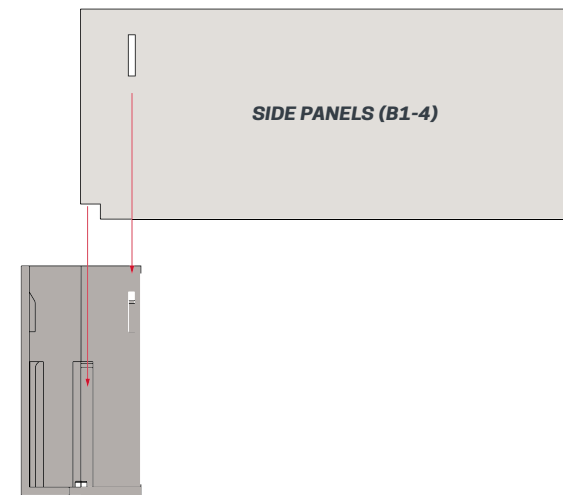

FIGURE 2



FIGURE 2-A

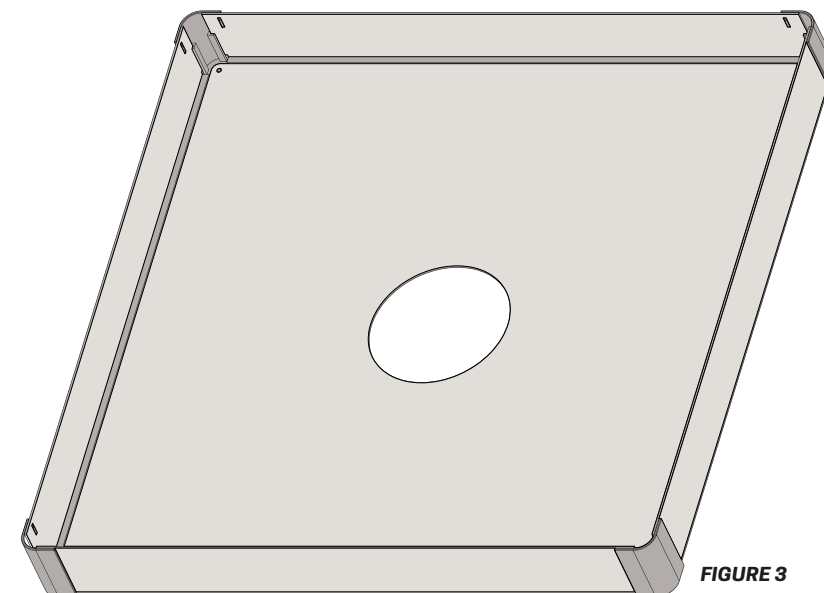

FIGURE 3

WARRANTY **RESIDENTIAL**

10YR WARRANTY

Frankford offers 9 oz. marine grade solution dyed acrylic fabric from several mills, including Sunbrella®, Outdura, and Recasens®. All marine grade acrylic fabrics we use carry a warranty of 10 years from the original date of purchase. All upholstery grade fabrics we use carry a warranty of 5 years from the original date of purchase.

The warranty protects against the loss of characteristics, rot, mildew, and colorfastness typical in normal atmospheric conditions. The product must be properly installed, maintained, and under normal use and environment.

This warranty does not cover damage caused by contact with foreign objects, abuse, negligence, vandalism, burns of any kind, improper cleaning techniques, normal wear, perforations, weather soiling, environmental pollution stains, natural disasters, or acts of nature. Damage caused by the storage method or location used by clients is not covered.

DISCLAIMER: When opening and closing the umbrella, the user must be sure all fabric is pulled away from the ribs to prevent unnecessary rubbing of the fabric against the frame or hardware. This could result in premature wearing or holes in the fabric. Damage of this nature is not covered under warranty.

The warranty, if applicable, does not cover labor, frames, systems, and installation supplied by the dealer or reseller. Replacement fabric canopy is covered for the time remaining in the original warranty and does not activate a new 10-year, or 5-year warranty.

5YR WARRANTY

Frankford warrants the crank mechanisms for a period of 5 years from the original date of purchase. This warranty includes manufacturer defects of crank handles, crank axles, crank spool, steel cable and para-cord.

Frankford warrants the frame structure for a period of 5 years from the original date of purchase. This warranty includes manufacturer defects to the notch, runner, mast and skeletal structure. This warranty does not include damages sustained to these umbrellas while in any degree of tilt or improper installation.

3YR FINISH WARRANTY

Frankford warrants all powder coat and anodized finishes for aluminum masts a period of 3 years from the original date of purchase. This warranty includes chipping, peeling, flaking, bubbling, and fading of the powder coat and anodized finishes on the aluminum masts only.

1YR WARRANTY

Frankford warrants all UMBRELLA BASES for a period of one (1) year from the original date of purchase.

DISCLAIMER: This warranty covers manufacturing defects only. It does not cover breakage due to contact with foreign objects, chipping of the finishes, crumbling of concrete, or any damage associated with transporting the base.

RUST DISCLAIMER

Rust is a natural part of the aging process for all steel and iron-based materials, therefore it is not considered a defect and is not covered under any Frankford Umbrellas' warranties. Steel bases and mounts are designed to require minimum maintenance and should be kept clean and well maintained.

GENERAL DISCLAIMER

Frankford Umbrellas' warranties do not cover damage to any umbrellas or umbrella bases related to extreme weather, abuse, misuse, or any damage that occurs as a result of contact with the ground or any other foreign object due to sudden and severe weather events or other extreme acts of nature.

Frankford Umbrellas' warranties are only applicable to products that are properly secured to Frankford bases or anchoring systems equal to or greater than recommended by Frankford. Failure to properly secure Frankford umbrellas to Frankford bases equal to or greater than recommended will void all warranties.

If warrantable damage occurs, Frankford will refinish, replace or repair any item in this category at its own discretion.

WARRANTY **COMMERCIAL**

7YR WARRANTY

Frankford offers 9 oz. marine grade solution dyed acrylic fabric from several mills, including Sunbrella®, Outdura, and Recasens®. All marine grade acrylic fabrics we use carry a warranty of 7 years from the original date of purchase. All upholstery grade fabrics we use carry a warranty of 5 years from the original date of purchase.

The warranty protects against the loss of characteristics, rot, mildew, and colorfastness typical in normal atmospheric conditions. The product must be properly installed, maintained, and under normal use and environment.

This warranty does not cover damage caused by contact with foreign objects, abuse, negligence, vandalism, burns of any kind, improper cleaning techniques, normal wear, perforations, weather soiling, environmental pollution stains, natural disasters, or acts of nature. Damage caused by the storage method or location used by clients is not covered.

DISCLAIMER: When opening and closing the umbrella, the user must be sure all fabric is pulled away from the ribs to prevent unnecessary rubbing of the fabric against the frame or hardware. This could result in premature wearing or holes in the fabric. Damage of this nature is not covered under warranty.

The warranty, if applicable, does not cover labor, frames, systems, and installation supplied by the dealer or reseller. Replacement fabric canopy is covered for the time remaining in the original warranty and does not activate a new 7-year, or 5-year warranty.

3YR WARRANTY

Frankford warrants the crank mechanisms for a period of 3 years from the original date of purchase. This warranty includes manufacturer defects of crank handles, crank axles, crank spool, steel cable and para-cord.

Frankford warrants the frame structure for a period of 3 years from the original date of purchase. This warranty includes manufacturer defects to the notch, runner, mast and skeletal structure. This warranty does not include damages sustained to these umbrellas while in any degree of tilt or improper installation.

3YR FINISH WARRANTY

Frankford warrants all powder coat and anodized finishes for aluminum masts a period of 3 years from the original date of purchase. This warranty includes chipping, peeling, flaking, bubbling, and fading of the powder coat and anodized finishes on the aluminum masts only.

1YR WARRANTY

Frankford warrants all UMBRELLA BASES for a period of one (1) year from the original date of purchase.

DISCLAIMER: This warranty covers manufacturing defects only. It does not cover breakage due to contact with foreign objects, chipping of the finishes, crumbling of concrete, or any damage associated with transporting the base.

RUST DISCLAIMER

Rust is a natural part of the aging process for all steel and iron-based materials, therefore it is not considered a defect and is not covered under any Frankford Umbrellas' warranties. Steel bases and mounts are designed to require minimum maintenance and should be kept clean and well maintained.

GENERAL DISCLAIMER

Frankford Umbrellas' warranties do not cover damage to any umbrellas or umbrella bases related to extreme weather, abuse, misuse, or any damage that occurs as a result of contact with the ground or any other foreign object due to sudden and severe weather events or other extreme acts of nature.

Frankford Umbrellas' warranties are only applicable to products that are properly secured to Frankford bases or anchoring systems equal to or greater than recommended by Frankford. Failure to properly secure Frankford umbrellas to Frankford bases equal to or greater than recommended will void all warranties.

If warrantable damage occurs, Frankford will refinish, replace or repair any item in this category at its own discretion.

FRANKFORD UMBRELLAS
NORTH AMERICAN HEADQUARTERS

110 Gaither Drive
Mount Laurel, New Jersey 08054
856-222-4134

Info@frankfordumbrellas.com
frankfordumbrellas.com

    @frankfordshade



FRANKFORD
exceptional shade